

# STEEL BEAST®

**JEI**  
Solutions  
Built for Industry

# PRO-WP 150 PRO-WP 300

## WELDING POSITIONERS



The welding positioners enable round or tubular pieces of metal to be rotated easily, provide better weld seam accessibility, can help produce high quality welds and increase deposition rates.

Frequency inverter ensures continuous speed adjustment and speed stabilization at the set value.

They reduce time and effort for the welders, who can focus on their job with no need to constantly move around their workspace in order to get the best position.

The compact design takes up minimal floor space and tilting up to 90 degrees improves ergonomics of the workspace. Selection of various auxiliary accessories make it possible to create an advanced modular welding station and customize it depending on required welding or cutting applications to maximize production efficiency.

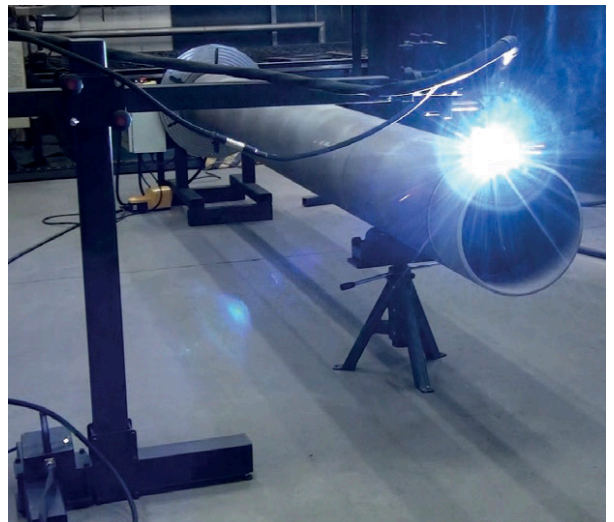

CALL **01706 229 490** TO BOOK YOUR DEMONSTRATION NOW OR VISIT **WWW.STEELBEAST.CO.UK**

[WWW.JEIUK.COM](http://WWW.JEIUK.COM)

PART NUMBER: PRO-WP 150 / PRO-WP 300

JEI Solutions



- ✓ Left or right rotation
- ✓ Continuous speed adjustment
- ✓ Speed stabilization within full speed range from 0,12 rpm up to 2,4 rpm
- ✓ Start/Stop (both controller and foot pedal)
- ✓ Arc ignition
- ✓ Remote control
- ✓ Foot pedal for hands-free operation (option)
- ✓ Heavy duty construction
- ✓ Lots of auxiliary accessories enable building a modular welding station tailored for various welding and cutting applications

### OPTIONAL ACCESSORIES FOR VARIOUS WELDING AND CUTTING APPLICATIONS:

#### Lathe self-centering chuck D250



External clamping diameter:  $\Phi$  90–250 mm  
Internal clamping diameter:  $\Phi$  6–110 mm,  
 $\Phi$  80–250 mm  
Product code: UCW-0681-18-00-00-0

#### Lathe self-centering chuck D400



External clamping diameter:  $\Phi$  120–400 mm  
Internal clamping diameter:  $\Phi$  15–210 mm,  
 $\Phi$  120–400 mm  
Product code: UCW-0681-17-00-00-0

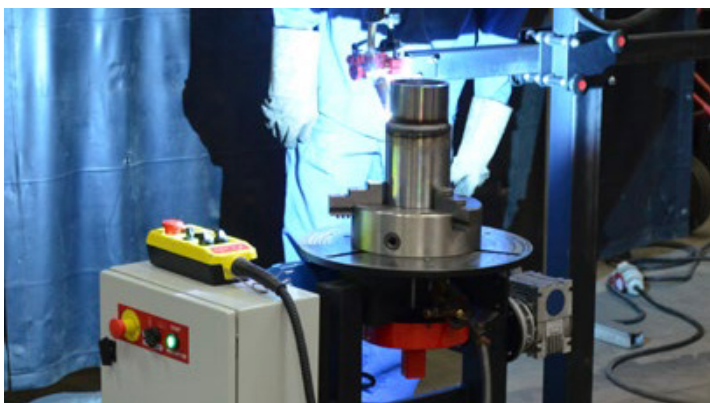
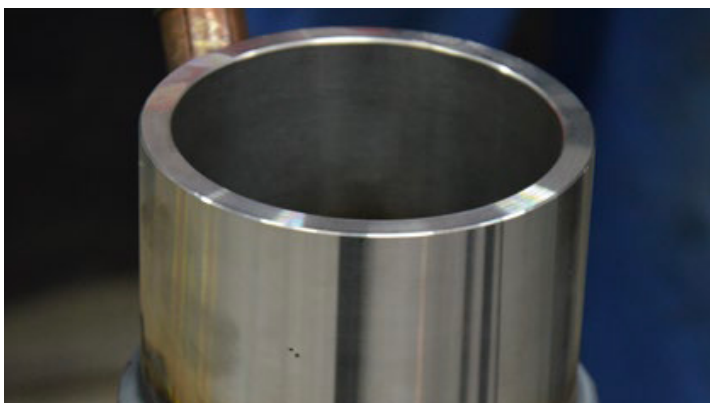
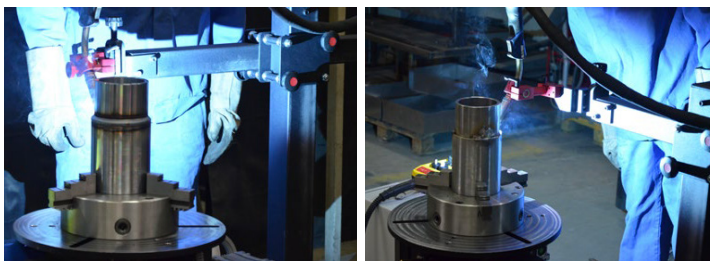

CALL **01706 229 490** TO BOOK YOUR DEMONSTRATION NOW OR VISIT **WWW.STEELBEAST.CO.UK**

### Keyless self-centering chuck DD300



**External clamping diameter:**  
Φ 170 – 280 mm

**Internal clamping diameter:**  
Φ 80 – 190 mm

**Product code:**  
UCW-0681-19-00-00-0

### Keyless self-centering chuck DD400



**External clamping diameter:**  
Φ 250 – 380 mm

**Internal clamping diameter:**  
Φ 120 – 250 mm

**Product code:**  
UCW-0681-20-00-00-0

### Torch Holder



To be fixed directly on positioner

**Product code:**  
UCW-0681-14-00-00-0

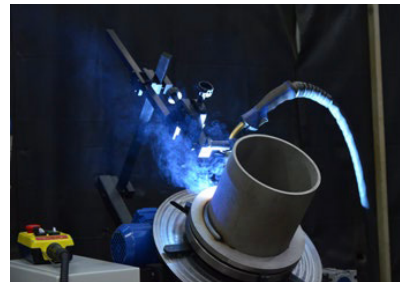
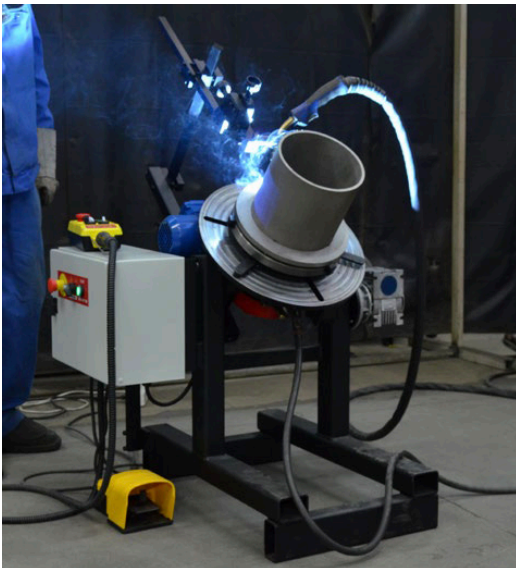

CALL **01706 229 490** TO BOOK YOUR DEMONSTRATION NOW OR VISIT **WWW.STEELBEAST.CO.UK**



### MINI C&B type PRO-WA 1X1



MINI C&B type PRO-WA 1X1	
Height	1160 mm
Length	1188 mm
Width	500 mm
Vertical movement range	810 mm
Horizontal movement range	815 mm
Maximum load with full extension of horizontal arm	7 kg

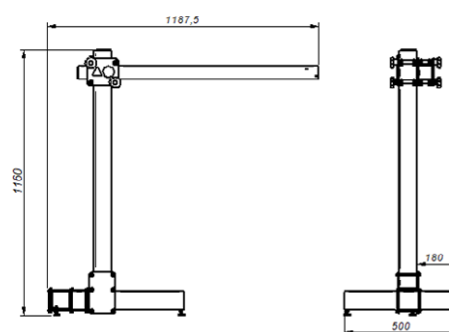

**Product code:**  
STJ-0709-10-00-00-0

### Cross slide assembly (option)



35 mm x 35 mm (left & right, up & down)

**Product code:**  
ZSP-0466-14-00-00-0



### Roller support



Load capacity: 1000 kg (2200 lbs)

**Product code:**  
WSP-0681-16-00-00-0



CALL **01706 229 490** TO BOOK YOUR DEMONSTRATION NOW OR VISIT [WWW.STEELBEAST.CO.UK](http://WWW.STEELBEAST.CO.UK)

### Pendulum Oscillator OSC-8



**Product code:**

OSC-0497-10-00-00-0

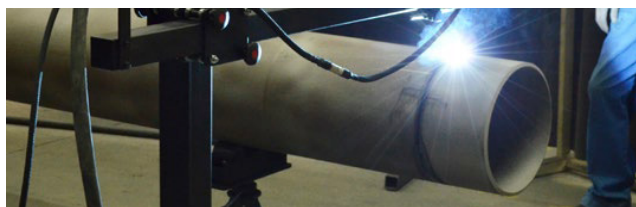
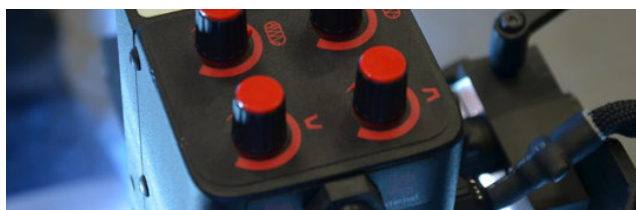

### Power Supply



**Product code:**

ZSL-0497-16-00-00-0 (230 V CEE)

ZSL-0497-16-00-01-0 (115 V USA)

ZSL-0497-16-00-02-0 (230 V AU)

ZSL-0497-16-00-03-0 (230 V UK, type G)

ZSL-0497-16-00-04-0 (230 V IN, type D)

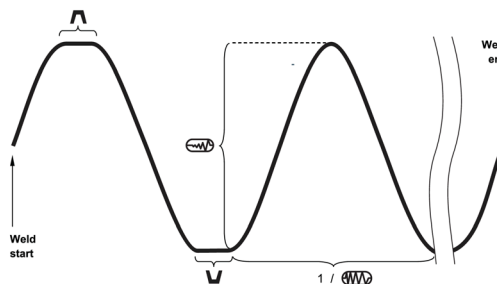

Parameter	Value	Description
	0-100%	Oscillation width
	0-100%	Oscillation speed
	0-3 s	Oscillation dwell time in the top position
	0-3 s	Oscillation dwell time in the bottom position

OSC-8 PENDULUM WEAVER	
Voltage	14-24 V DC
Power	50 W
Torch type	MIG/MAG
Torch diameter	16-22 mm (5/8-7/8")
Oscillation type	Pendulum
Oscillation width at r=150 mm (6")	1-30 mm (1-100%) 1/32-1-3/16" (1-100%)
Oscillation speed at oscillation width of 10 mm (3/8") and zero dwell time on ends	12-115 cycles/min (1-100%)
Oscillation dwell time on ends	0-3 s
Maximum torque	8 N·m (5.7 lb·ft)
Required ambient temperature	0-50°C (32-122°F)
Weight	2 kg (4 lbs)
Product code:	OSC-0497-10-00-00-0

CALL 01706 229 490 TO BOOK YOUR DEMONSTRATION NOW OR VISIT [WWW.STEELBEAST.CO.UK](http://WWW.STEELBEAST.CO.UK)

### Clamping accessories for welding torches (to choose from)



Short rod torch holder  
with clamp 16–22 mm

**Product code:** UCW-0476-20-00-00-0



Long rod torch holder  
with clamp 16–22 mm

**Product code:** UCW-0466-04-00-00-0



Short low rod torch holder  
with clip 16–22 mm

**Product code:** UCW-0476-06-00-00-0



Short rod torch holder  
with clip 16–22 mm

**Product code:** UCW-0476-27-00-00-0



Long rod torch holder  
with clip 16–22 mm

**Product code:** UCW-0466-22-00-00-0

### Clamping accessories for cutting torches (to choose from)



Rod 150 mm for cutting torch holders

**Product code:** SLP-0233-13-02-00-1



Standard torch holder with clamp 28–  
35 mm and rough angle adjustment

**Product code:** UCW-0475-28-00-00-0



Precise torch holder with clamp 28–  
35 mm and precise angle adjustment

**Product code:** UCW-0475-08-00-00-0



Standard machine torch holder for oxy-fuel cutting with  
vertical position setting and rough angle adjustment

**Product code for 30 mm torch with rack:**

UCW-0475-61-00-00-0

**Product code for 35 mm torch with rack:**

UCW-0475-29-00-00-1



Precise machine torch holder for oxy-fuel cutting with  
vertical position setting and precise angle adjustment.

**Product code for 30 mm torch with rack:**

UCW-0475-59-00-00-0

**Product code for 35 mm torch with rack:**

UCW-0475-42-00-00-1

CALL **01706 229 490** TO BOOK YOUR DEMONSTRATION NOW OR VISIT **WWW.STEELBEAST.CO.UK**

### Clamping set

Product code: ZST-0681-15-00-00-0



Clamp 100mm x 32mm x 19mm (3 pcs)



Clamp 150mm x 32mm x 22mm (3 pcs)



Step block 28mm x 20mm - 38mm (4 pcs)



Step block 35mm x 28mm - 64mm (4 pcs)



Step block 98mm x 64mm - 152mm (4 pcs)



Flanged nut M10 x 15mm (6 pcs)



Extension nut M10 x 30mm long (4 pcs)

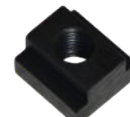

T-slot nut 12mm x 18mm x 14mm (6 pcs)

- Double end stud bolt 75mm x 30mm (4 pcs)
- Double end stud bolt 100mm x 30mm (4 pcs)
- Double end stud bolt 125mm x 30mm (4 pcs)
- Double end stud bolt 150mm x 30mm (4 pcs)
- Double end stud bolt 175mm x 30mm (4 pcs)
- Double end stud bolt 200mm x 30mm (4 pcs)



The arc ignition allows the welding torch to be switched on and off remotely.

Technical specification	PRO-WP150	PRO-WP300
Voltage	1~ 220-240 V, 50-60 Hz 1~ 100-120 V, 50-60 Hz	1~ 220-240 V, 50-60 Hz 1~ 100-120 V, 50-60 Hz
Power	0,25 kW	0,25 kW
Speed range min/max	0,12 - 2,4 rpm	0,12 - 2,4 rpm
Max load capacity	150 kg (331 lbs)	300 kg (661 lbs)
Mass center offset from the table at a 90 ° tilt	up to 100 mm	up to 100 mm
Faceplate diameter	450 mm (17.7")	630 mm (24.8")
Hollow-shaft inside diameter	28 mm (1.1")	28 mm (1.1")
Tilting range with continuous angle adjustment	0-90 °	0-90 °
Tilting	manual	manual
Max. welding current transfer	400 A	400 A
Weight	115 kg (254 lbs)	150 kg (330 lbs)
Product code:	PZY-0681-10-10-00-0	PZY-0682-10-10-00-0

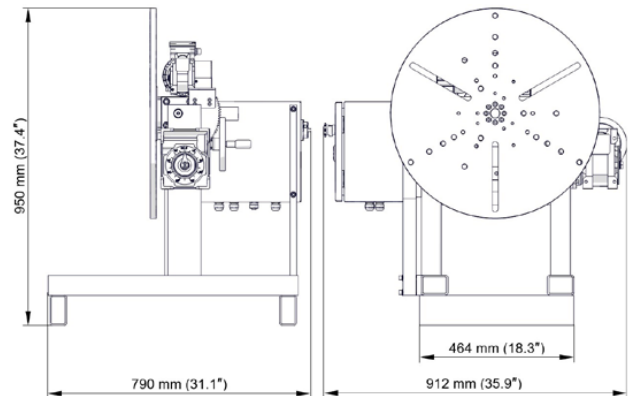
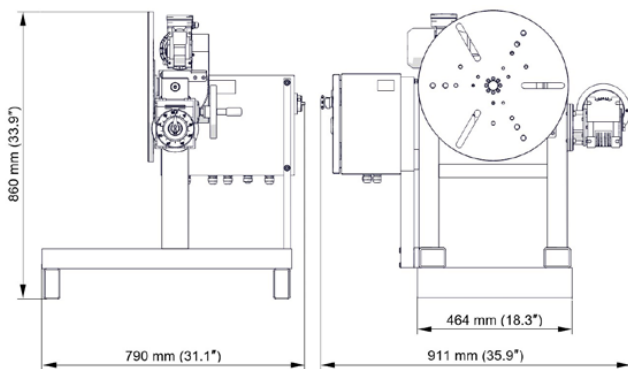

CALL 01706 229 490 TO BOOK YOUR DEMONSTRATION NOW OR VISIT [WWW.STEELBEAST.CO.UK](http://WWW.STEELBEAST.CO.UK)