

OPERATOR'S MANUAL

Mini Spider WELDING CARRIAGE



Unit 21 Empire Business Park, Enterprise Way
Burnley, Lancashire, BB12 6LT

Tel: 00 44 1706 229490 Email: sales@jeisolutions.co.uk

Contents

1. GENERAL INFORMATION	3
1.1. Application	3
1.2. Technical data.....	3
1.3. Equipment included	4
1.4. Dimensions	5
1.5. Design	6
2. SAFETY PRECAUTIONS.....	7
3. STARTUP AND OPERATION	9
3.1. Operating.....	9
3.2. Troubleshooting	11
4. MAINTENANCE	12
5. ACCESSORIES	13
5.1. Battery 5.2 Ah	13
5.2. Battery charger	13
5.3. Power supply and power cord.....	14
5.4. Auxiliary magnet blocks	15
5.5. Cable anchor	16
6. WIRING DIAGRAM	17
7. DECLARATION OF CONFORMITY	18
8. QUALITY CERTIFICATE.....	19
9. WARRANTY CARD.....	20

1. GENERAL INFORMATION

1.1. Application

The Mini Spider is a battery-powered welding carriage designed to make fillet welds by using MIG/MAG torches. It is clamped to the surface with permanent magnets.

An optional magnet blocks increase the clamping force. An optional power supply can be used to connect the carriage to a 110–240 V power source.

1.2. Technical data

Voltage	18 V DC, 5.2 Ah
Power	25 W
Welding position (according to EN ISO 6947 and AWS/ASME)	PA / 1F PB / 2F
Torch type	MIG/MAG
Torch diameter	16–22 mm (0.63–0.87")
Maximum allowed cable weight for horizontal work	8 kg (18 lbs)
Minimum workpiece thickness	4 mm (0.16")
Ground clearance	4 mm (0.16")
Horizontal pulling force	150 N
Cross slides adjustment range	0–21 mm (0–0.83") up-down, left-right
Horizontal speed*	5–110 cm/min (2–44 in/min)
Weight (without the battery)	7.6 kg (16.8 lbs)

* When the battery is fully charged.

1.3. Equipment included

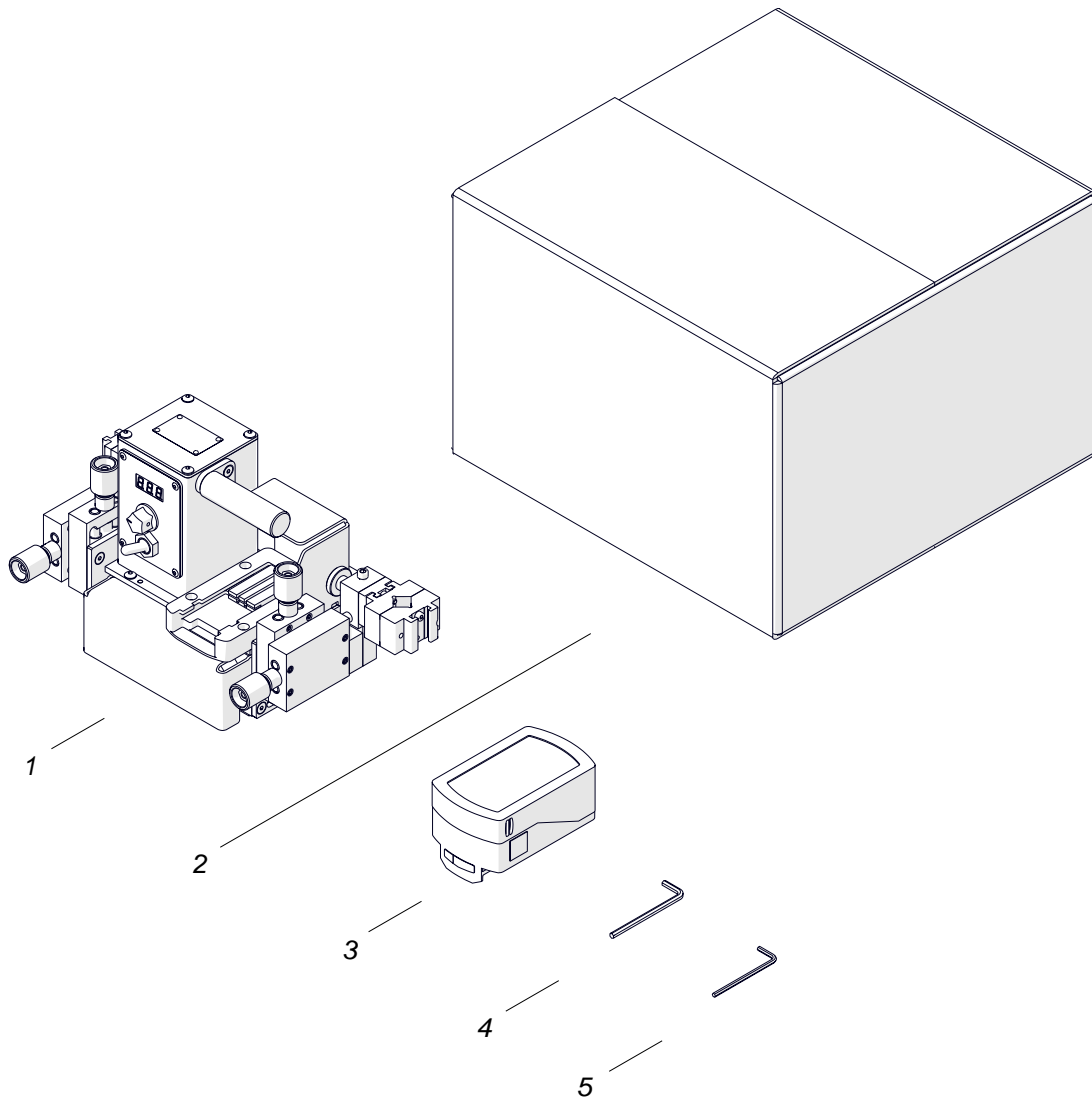

1	Carriage	1 unit
2	Cardboard box	1 unit
3	Battery	1 unit
4	4 mm hex wrench	1 unit
5	3 mm hex wrench	1 unit
–	Operator's Manual	1 unit

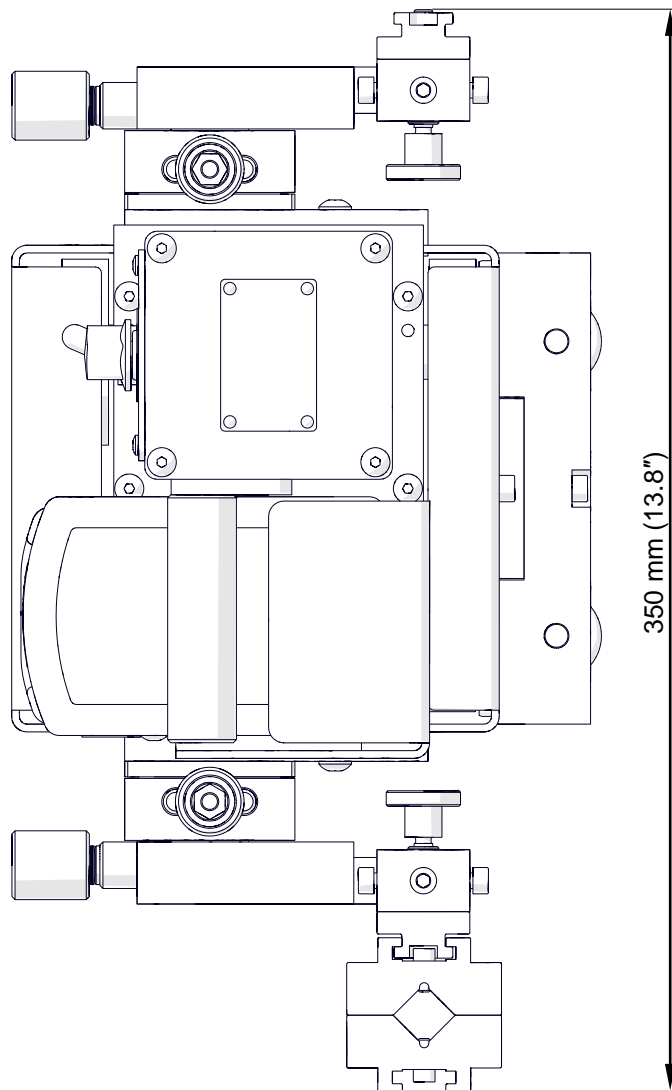
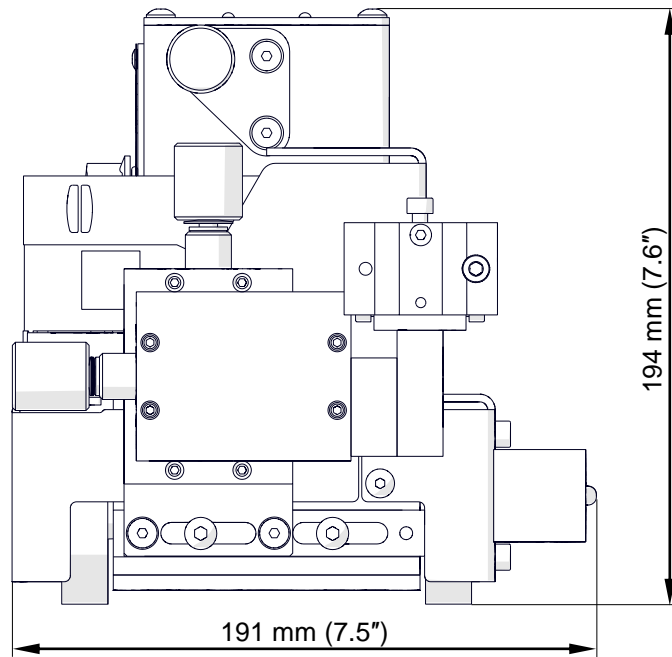
1.4. Dimensions

1.5. Design

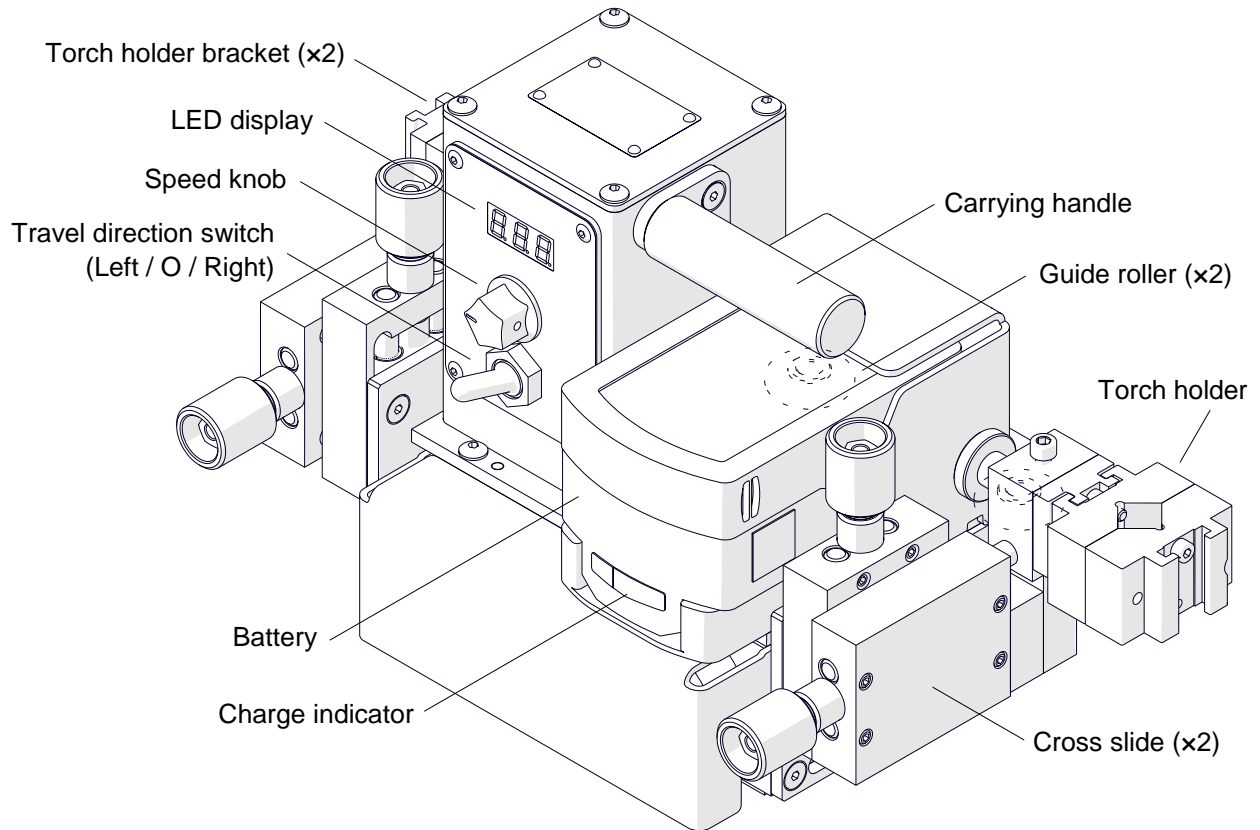

2. SAFETY PRECAUTIONS

1. Before you start, read this Operator's Manual and complete occupational safety and health training.
2. Use only in applications specified in this Operator's Manual.
3. Make sure that the carriage has all parts and they are genuine and not damaged.
4. Make sure that the specifications of the power source are the same as those specified on the rating plate.
5. When you use a power supply, connect it to a correctly grounded power source.
6. Do not carry the carriage by the cords, and do not pull them. This can cause damage and electric shock.
7. Keep untrained bystanders away from the carriage.
8. Before each use, ensure the correct condition of the carriage, battery, power supply, power source, cords, control parts, rollers, and wheels.
9. Before each use, make sure that no part is cracked or loose. Make sure to maintain correct conditions that can have an effect on the operation of the carriage.
10. Keep the carriage dry. Do not expose it to rain, snow, or frost.
11. Keep the work area well lit, clean, and free of obstacles.
12. Do not use near flammable materials, or in explosive environments.
13. Move and put the carriage by using the carrying handle.
14. Put the carriage so that all four wheels are on the surface. Make sure that no contact is between the surface and chassis.
15. Install the battery / power supply only after you set the travel direction switch to the middle position.
16. Install only torches whose diameter matches the diameter of the torch holder.
17. Make sure that the torch cables are not on the surface. Hang them to decrease the load on the carriage. Use only cables whose weight is not more than 8 kg (18 lbs).
18. At heights, use a protection to not let the carriage fall.
19. Do not stay below the carriage that is put at heights.
20. Use ear and eye protection (helmet, shield, and screen), gloves, and protective clothing. Do not use loose clothing.
21. Do not try to stop the travel by hand. To stop, set the travel direction switch to the middle position.
22. Maintain only after you remove the battery / power supply.

23. Repair only in a service center appointed by the seller.
24. If the carriage falls, is wet, or has any damage, stop the work and promptly send the carriage to the service center for check and repair.
25. Do not leave the carriage unattended during work.
26. If you are not going to use the carriage, remove it from the worksite and keep it in a safe and dry place.

3. STARTUP AND OPERATION

3.1. Operating

Put the battery into the charger. Let the battery charge until the light on the charger stops flashing and stays on.

Use the carrying handle to move the carriage to the worksite. Set the travel direction switch to the middle position (1) and put the battery onto the carriage (2).

Then, the display comes on (8.8.8.). Next, if the unit of speed is set to centimeters per minute, *CM* shows. If the unit is set to inches per minute, *IN* shows.

Use the 3 mm and 4 mm hex wrenches to tighten the torch in the holder (3).

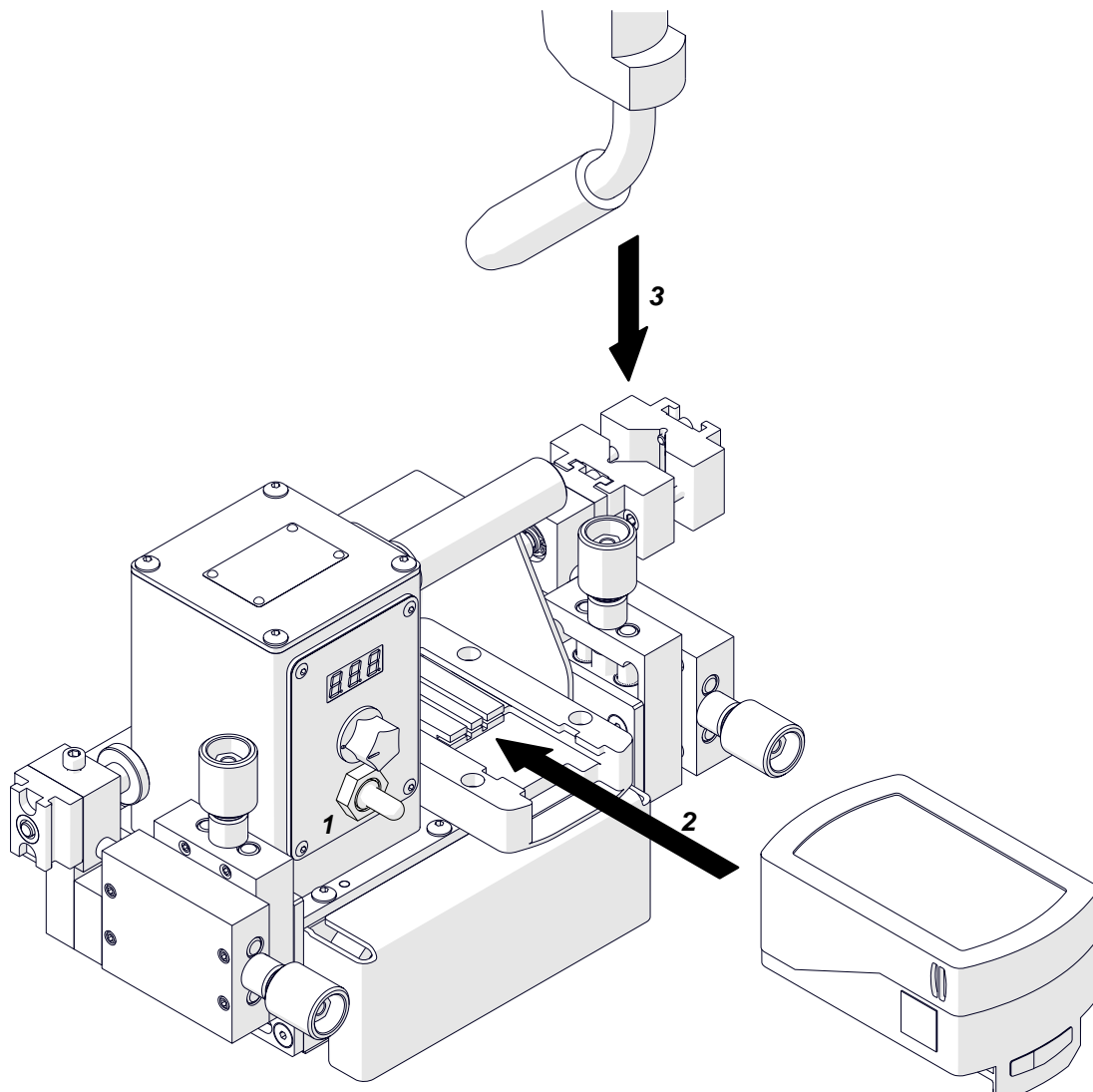

To work in narrow spaces, adjust the position of the cross slides. On the two sides, loosen the screws (4). Then, move the cross slides (5) and tighten the screws (4).

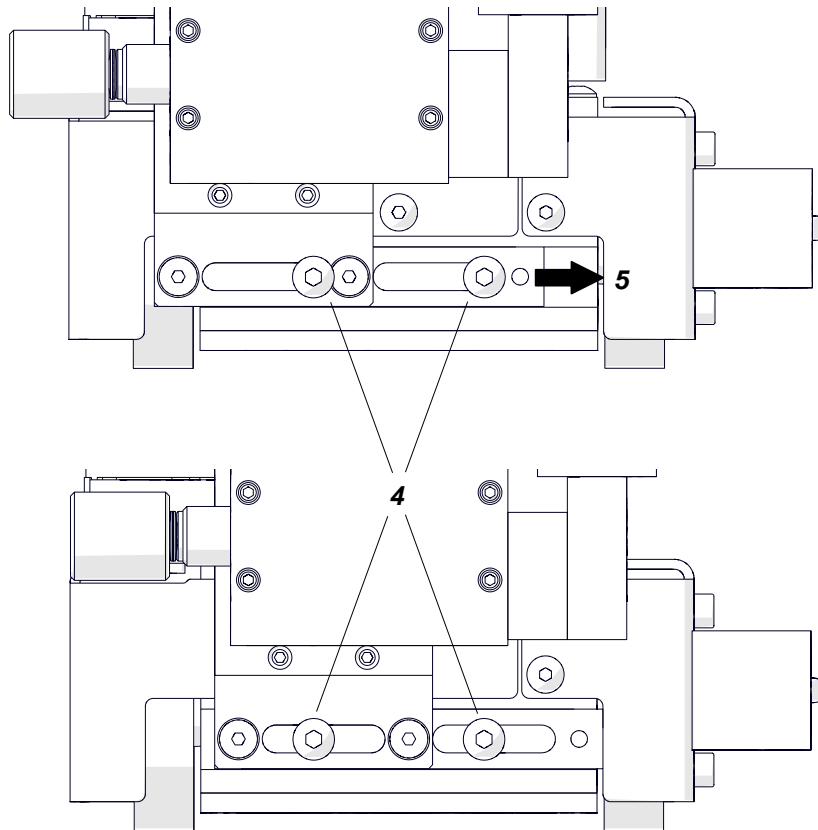

Put the carriage so that the rollers are on the workpiece. Then, use the knobs (6) to put the torch in the welding joint.

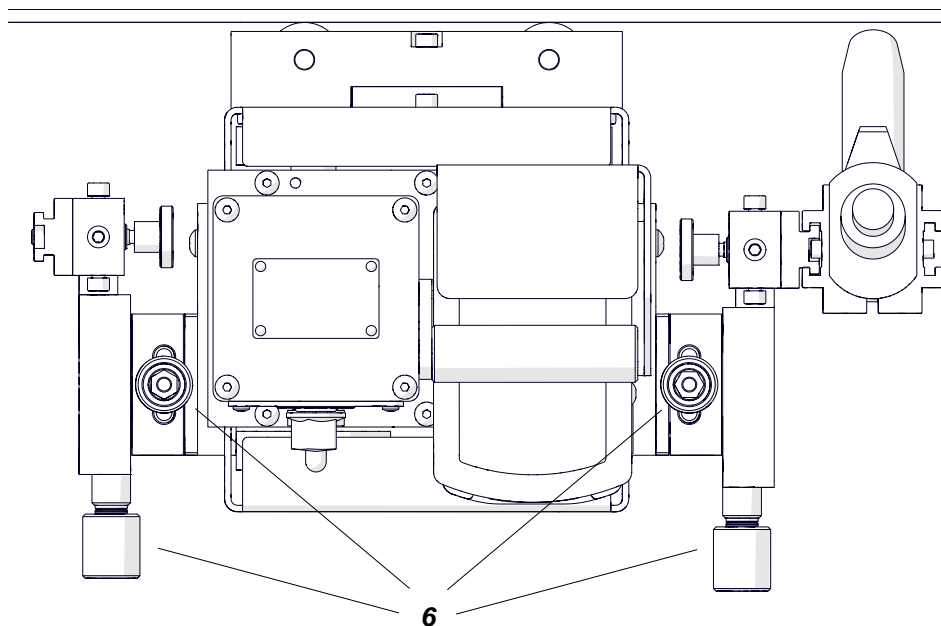

Use the speed knob to set the required speed. Use the travel direction switch to select a direction of travel. This will start the travel with the speed that is shown.

To stop the travel, set the travel direction switch to the middle position.

If you do not use the carriage for 2.5 minutes, it goes to the sleep mode. To go back from the sleep mode, use a travel direction switch. When the battery is discharged, the travel stops. Then, recharge the battery. To check the charge level, press the button on the charge indicator.

After the work is finished, remove the battery / power supply.

3.2. Troubleshooting

Message	Problem	Solution
7.55.	Not all display segments are on after powering.	Contact service center for check and repair.
Eur	Speed is shown in centimeters per minute instead of inches per minute.	Contact service center.
US	Speed is shown in inches per minute instead of centimeters per minute.	Contact service center.
Err	Travel direction switch is not set to the middle position when powering.	Set the travel direction switch to the middle position.
bAt	Battery discharged. The carriage stops.	Charge the battery or replace to a fully charged.

4. MAINTENANCE

Each day:

1. Clean the chassis, rollers, and wheels.
2. Make sure that the rollers rotate freely.
3. Clean the torch nozzle. Replace if damaged.
4. Examine the battery. Replace if damaged.

Each month:

1. Make sure that the knob and the switch work as intended. Replace if loose or damaged.
2. Examine cables and cords. Replace if damaged.
3. Tighten screws if loose.

5. ACCESSORIES

5.1. Battery 5.2 Ah

Part number:
AKM-000086

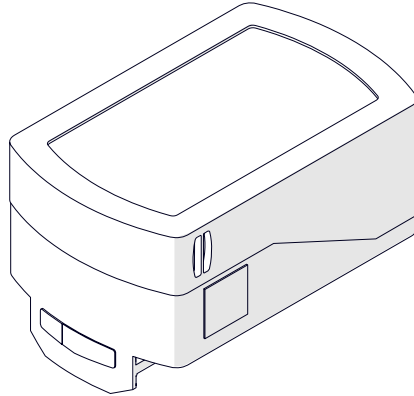

5.2. Battery charger

Recharges the battery from 220–240 V or 120 V power source.

Part number:
LDW-000006 (220–240 V, 50/60 Hz)
LDW-000007 (120 V, 60 Hz)

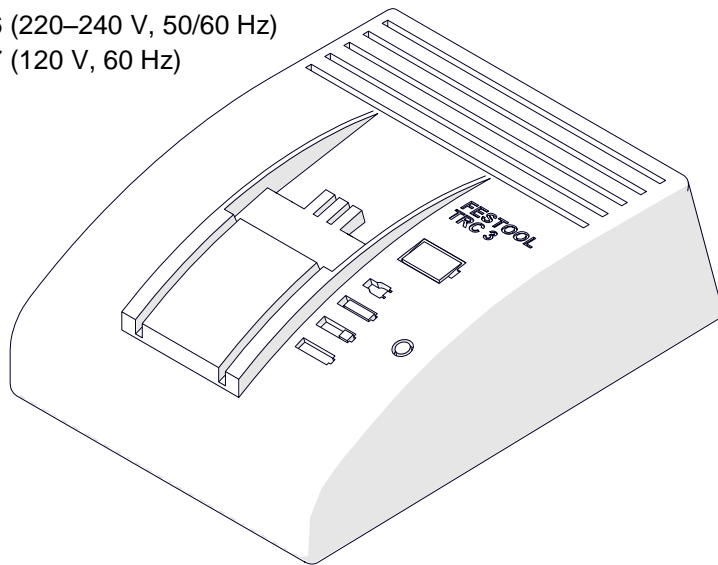

5.3. Power supply and power cord

Allows connecting the carriage to a 110–240 V power source instead using the battery. The length of the power cord is 3 m (10 ft).

Part number (power supply):
ZSL-0526-20-00-00-0

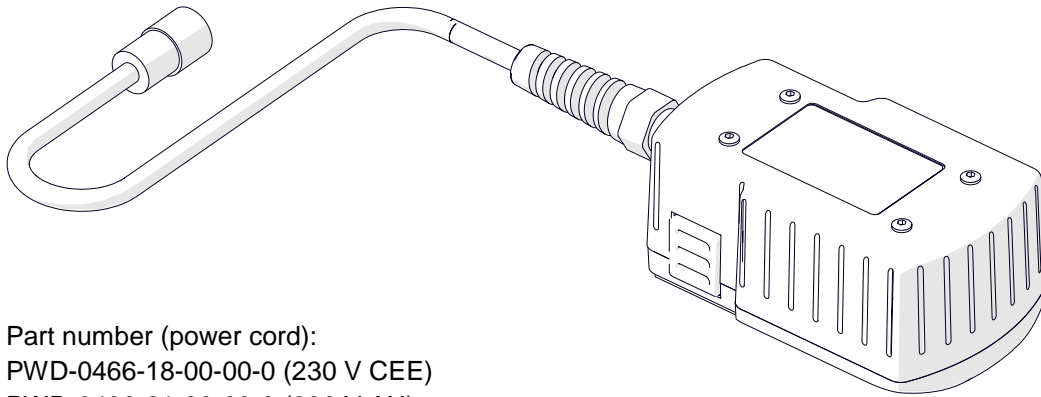

Part number (power cord):
PWD-0466-18-00-00-0 (230 V CEE)
PWD-0466-21-00-00-0 (230 V AU)
PWD-0466-31-00-00-0 (230 V IN)
PWD-0466-16-00-00-0 (115 V USA)
PWD-0466-28-00-00-0 (115 V UK)

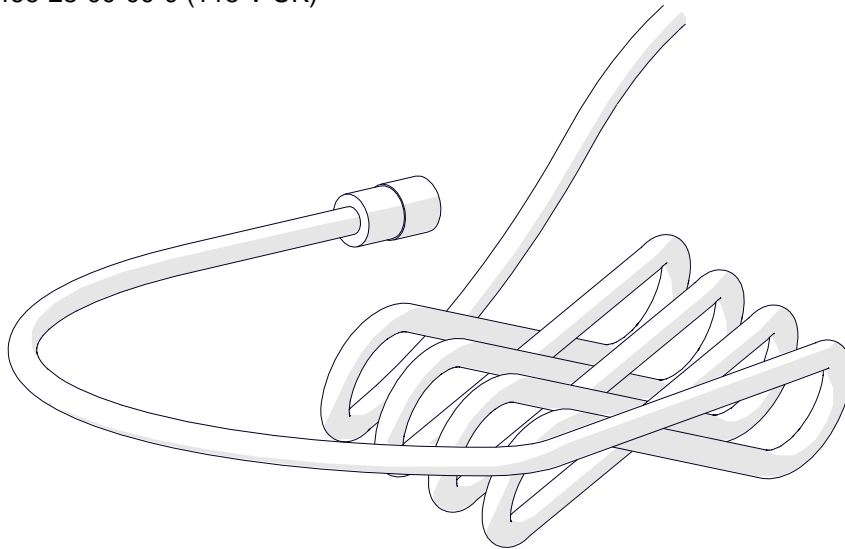

5.4. Auxiliary magnet blocks

The blocks increase the clamping force of the carriage.

Part number:
ZST-0655-09-00-00-0
(holding force: 2x50 N)

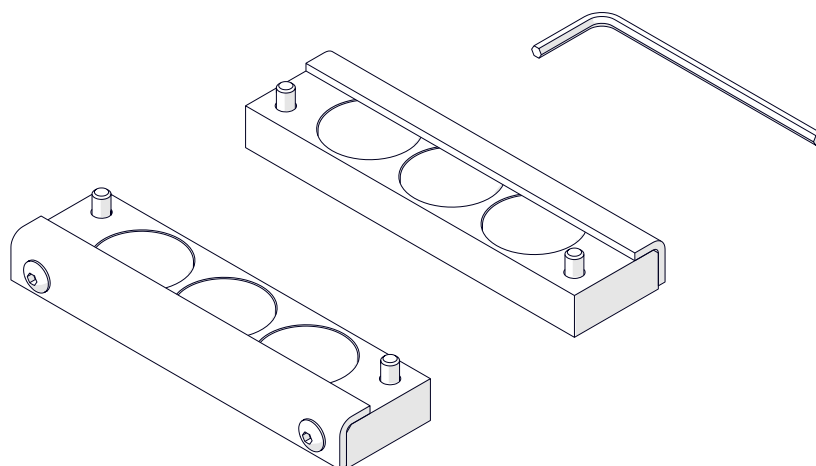

Use the 2.5 mm hex wrench to attach the blocks to the carriage.

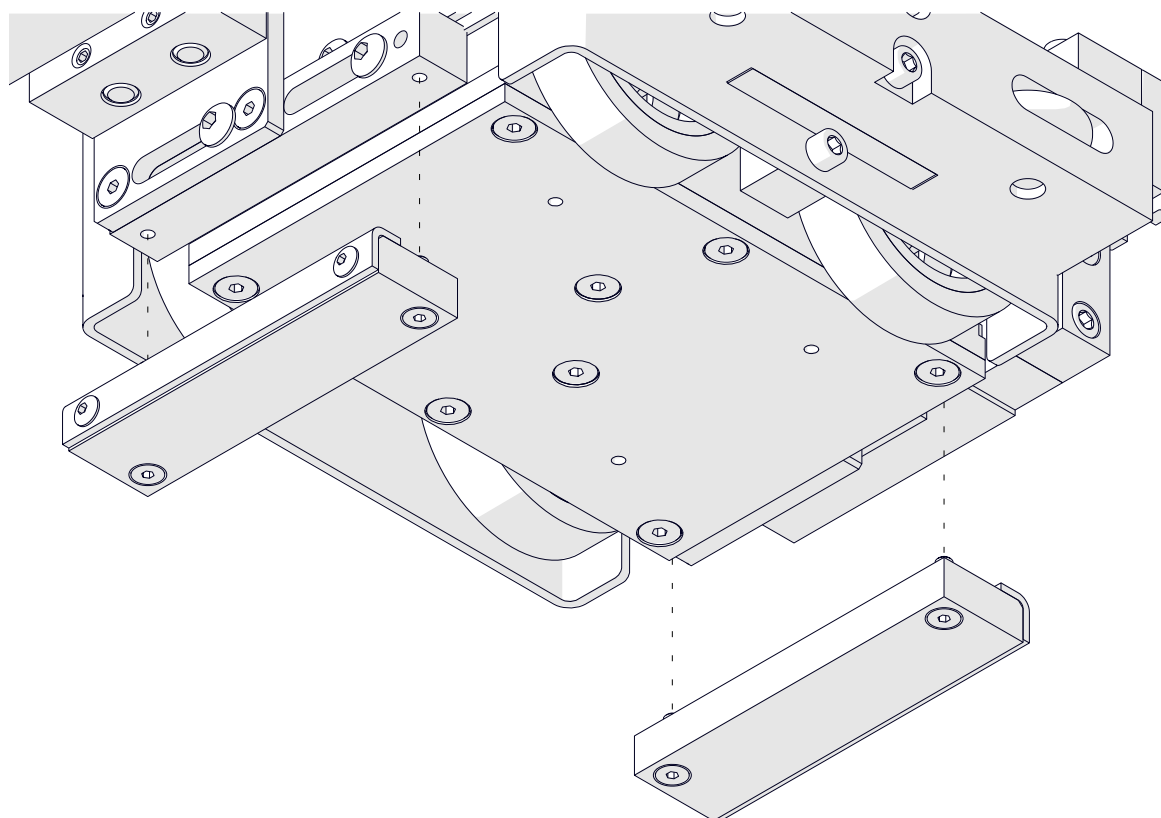

5.5. Cable anchor

Attaches the gas cables and the power cord to decrease the load applied on the torch holder. Install the anchor on the carrying handle.

Part number:
PDT-0526-21-00-00-0

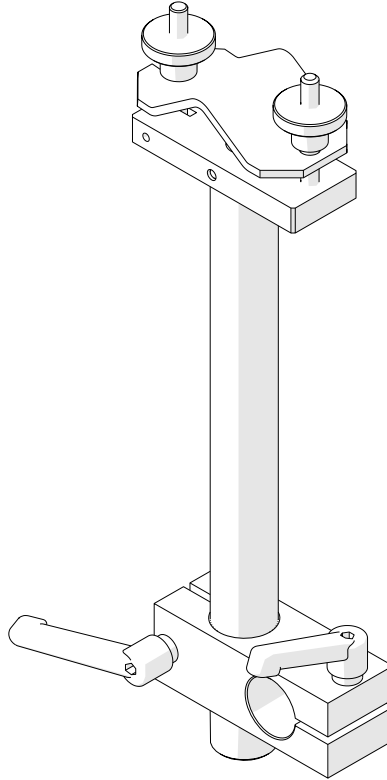

6. WIRING DIAGRAM

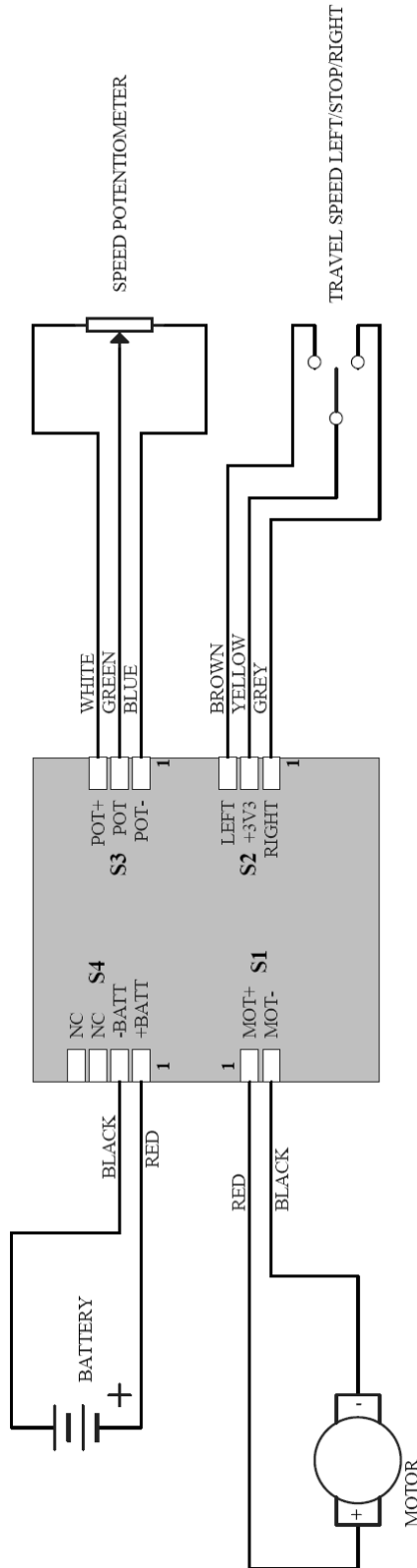

7. DECLARATION OF CONFORMITY

EC Declaration of Conformity

We

***JEI Group Ltd
T/A JEI Drilling & Cutting Solutions Ltd
Unit 21 Empire Business Park
Enterprise Way, Burnley
Lancashire, BB12 6LT***

declare with full responsibility that:

Mini Spider Welding Carriage

is manufactured in accordance with the following standards:

- EN 12100
- EN 60204-1
- EN 60974-10

and satisfies safety regulations of the guidelines: 2014/30/EC, 2014/35/EC, 2006/42/EC.

Person authorized to compile the technical file:

David McFadden, Managing Director



Burnley, 11 October 2018

David McFadden

8. QUALITY CERTIFICATE

**Machine control card
Mini Spider Welding Carriage**

Serial number

Electric test

Type of test	Result	Name of tester
Insulation electrical strength test (1000 V, 50 Hz)	 Date
Continuity test of the protective earth system Ω Signature

Quality control

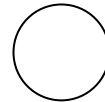

Adjustments, inspections

Quality control

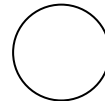

9. WARRANTY CARD**WARRANTY CARD No.....**

..... in the name of Manufacturer warrants the Mini Spider Welding Carriage to be free of defects in material and workmanship under normal use for a period of 12 months from the date of sale.

This warranty does not cover wheels as well as damage or wear that arise from misuse, accident, tempering, or any other causes not related to defects in workmanship or material.

Date of production

Serial number

Date of sale

Signature of seller.....

1.00 / 22 October 2018

WE RESERVE THE RIGHT TO MAKE CHANGES IN THIS MANUAL WITHOUT NOTICE