



OPERATOR'S MANUAL

WELDING CARRIAGE

Rail Bull 2



Unit 21 Empire Bus Park, Enterprise Way, Burnley, Lancs, BB12 6LT

Phone: 01706 229490, Fax: 01706 507347

www.steelbeast.co.uk e-mail: sales@jeisolutions.co.uk

Contents

1. GENERAL INFORMATION	3
1.1. Application	3
1.2. Technical data.....	4
1.3. Equipment included	5
1.4. Dimensions	6
1.5. Design	7
2. SAFETY PRECAUTIONS.....	8
3. STARTUP AND OPERATION	10
3.1. Assembling the hi-flex, semi-flex, and rigid track.....	10
3.2. Assembling the ring track.....	12
3.3. Positioning on a straight track	14
3.4. Positioning on a curved track	16
3.5. Preparing and connecting	17
3.6. Connecting to the welding circuits.....	18
3.7. Operating.....	19
3.8. Adjusting the pressure of rollers.....	25
3.9. Adapting for seam tracking (option).....	26
3.10. Troubleshooting	30
4. MAINTENANCE	31
5. ACCESSORIES	32
5.1. Seam tracking attachment.....	32
5.2. Tracking sensor tips.....	32
5.3. Motorized vertical slide.....	33
5.4. 0.5 m (1.5 ft) signal cable.....	33
5.5. Hi-flex track.....	34
5.6. Semi-flex track	35
5.7. Rigid track.....	35
5.8. Rack adjustment tool.....	35
5.9. Contact block	36
5.10. Magnetic units.....	37
5.11. Semi-flex track support.....	42
5.12. Vacuum track system.....	43
5.13. Ring tracks	44
5.14. Ring track supports	46
5.15. Torch holders, clamps, and rods	47
5.16. Transport attachment	49
5.17. Pendulum oscillator.....	49
6. WIRING DIAGRAM	52
7. DECLARATION OF CONFORMITY	55
8. WARRANTY CARD.....	56

1. GENERAL INFORMATION

1.1. Application

The Rail Bull 2 is a track carriage designed to cut and to make butt and fillet welds with or without oscillation. The carriage allows MIG/MAG, oxy-fuel, or plasma torches. The track is clamped with magnetic units to ferromagnetic surfaces that are flat or curved.

Accessories allow using torches with a larger diameter, guiding the carriage on a hi-flex, semi-flex, rigid, or ring track, and tracking the welding seam. Using a vacuum track system allows the track to be clamped to surfaces that are non-ferromagnetic.

Two intended configurations are shown in the figure that follows.

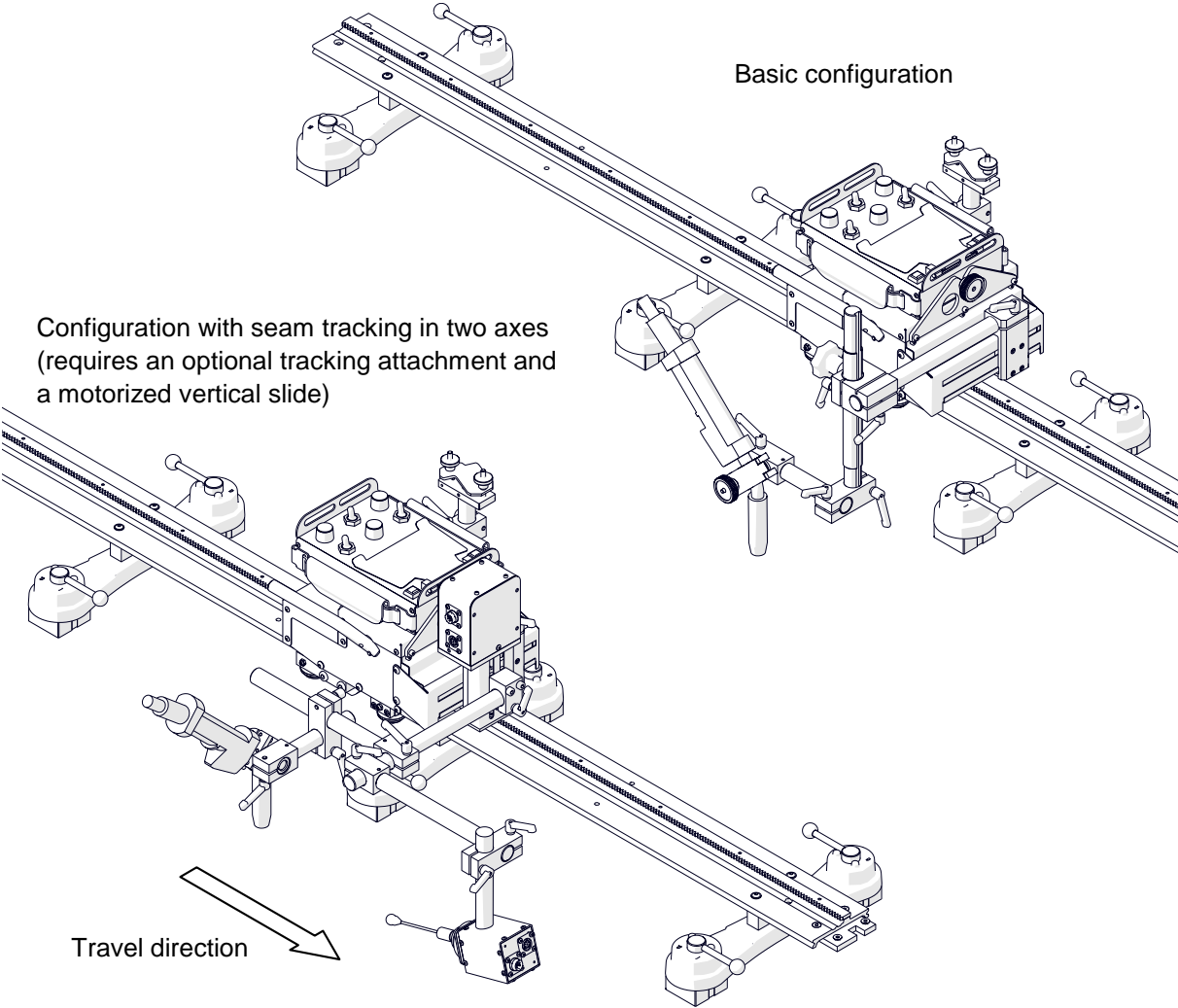

1.2. Technical data

Voltage		1~ 230 V, 50–60 Hz 1~ 115 V, 50–60 Hz 1~ 42 V, 50–60 Hz (60 V DC)
Power		120 W
Welding position (according to EN ISO 6947 and AWS/ASME)	Horizontal	PA/1F/1G PB/2F PC/2G PD/4F PE/4G
	Vertical	PF/3G PG/3F (contact your dealer) PG/3G
Diameter of round workpiece	Ring tracks (OD)	200 mm (8") – 3 m (10 ft)
	Hi-flex tracks (OD)	Minimum 1.5 m (5 ft)
	Hi-flex tracks (ID)	Minimum 3.4 m (11 ft)
	Custom rolled tracks (OD)	3–10 m (10–32 ft) (contact your dealer)
	Semi-flex tracks (OD)	Minimum 10 m (32 ft)
Torch type		MIG/MAG, oxy-fuel, plasma
MIG/MAG torch diameter		16–22 mm (0.63–0.87")
Minimum workpiece thickness for magnetic clamping		5 mm (0.2")
Horizontal pulling force		400 N
Vertical pulling force		300 N
Horizontal speed		0–300 cm/min (0–120 in/min)
Vertical speed		0–300 cm/min (0–120 in/min)
Oscillation type		Linear
Weld path		Straight, triangle, trapezoid, square
Oscillation width		0.2–11.8 cm (0.1–4.5")
Oscillation speed		10–300 cm/min (5–120 in/min)
Oscillation dwell time at center and on ends		0–5 s
Maximum oscillator pulling force		100 N
Allowed ambient temperature		0–45°C (32–113°F)
Maximum allowed ambient humidity without condensation		80%
Protection level		IP 23
Weight		10 kg (22 lbs)

1.3. Equipment included

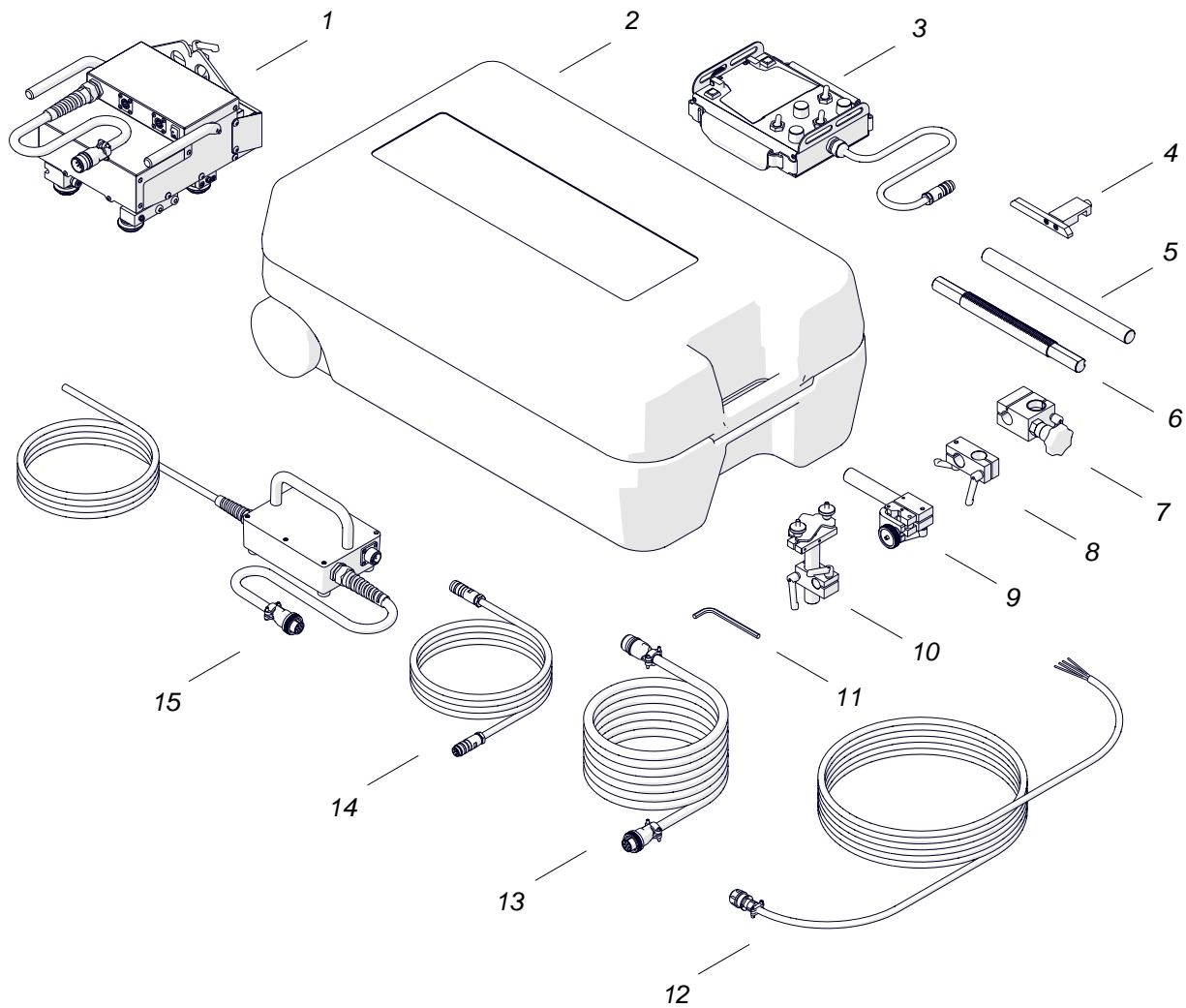

1	Carriage	1 unit
2	Plastic box	1 unit
3	Remote control	1 unit
4	Contact block	1 unit
5	300 mm (12") rod	1 unit
6	300 mm (12") rack with 180 mm (7") adjustment	1 unit
7	Rack holder	1 unit
8	Clamping block with levers	1 unit
9	Short rod torch holder with clamp	1 unit
10	Cable anchor	1 unit
11	6 mm hex wrench	1 unit
12	6.5 m (21 ft) arc ignition cable	1 unit
13	5 m (17 ft) power cable	1 unit
14	3 m (10 ft) remote control cable	1 unit
15	Power supply*	1 unit
-	Operator's Manual	1 unit

* 230 V, 115 V, or 42 V depending on the order

1.4. Dimensions

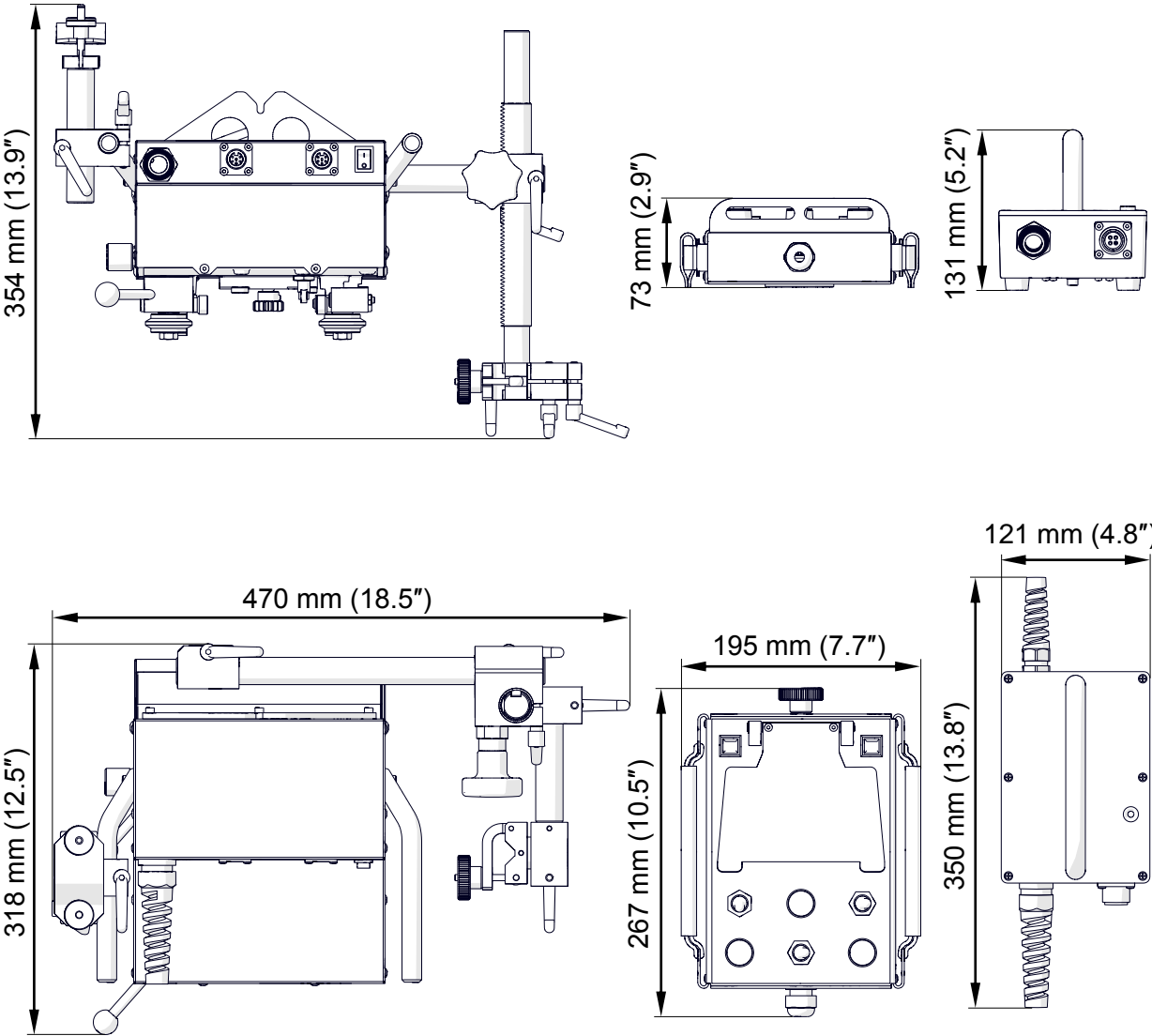

1.5. Design

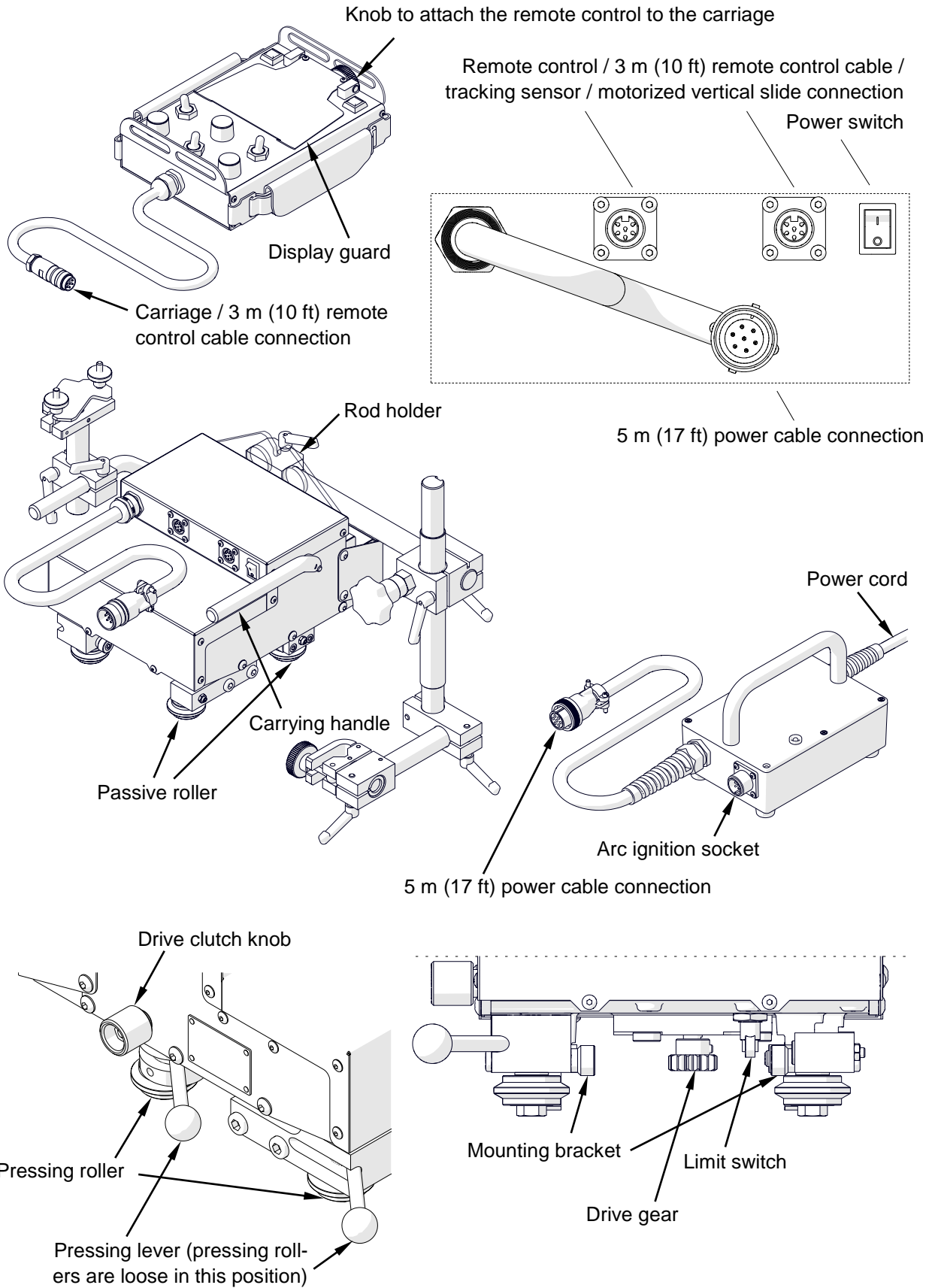

This document is protected by copyrights.

Copying, using, or distributing without permission of JEI Group Ltd is prohibited.

2. SAFETY PRECAUTIONS

1. Before use, read this Operator's Manual and complete a training in occupational safety and health.
2. Use only in applications specified in this Operator's Manual.
3. Make sure that the carriage, power supply, remote control, and other equipment have all parts. Make sure that all parts are genuine and not damaged.
4. Make sure that the specifications of the power source are the same as those specified on the rating plate.
5. Connect the carriage to the power supply by using the power cable. Connect the power supply to a correctly grounded power source.
6. Do not carry the carriage, remote control, and other equipment by cords or cables. Do not pull the cords or cables. This can cause damage and electric shock.
7. Keep untrained bystanders away from the carriage.
8. Before each use, ensure the correct condition of the carriage, power supply, remote control, and other equipment, power source, cords, cables, connections, rollers, and gear.
9. Before each use, make sure that no part is cracked or loose. Make sure to maintain correct conditions that can have an effect on the operation of the carriage.
10. Keep the carriage, power supply, remote control, and other equipment dry. Do not expose them to rain, snow, or frost.
11. Keep the worksite well lit, clean, and free of obstacles.
12. Do not use near flammable materials, or in explosive environments.
13. Transport and position the carriage by using the carrying handles.
14. Install the carriage only on the supplied track.
15. Make sure that the gear and rollers are clean.
16. Connect the cords and cables only after you set the power switch to 'O'.
17. Keep the sockets clean. Do not use high pressure during cleaning.
18. Install only torches whose diameter matches the diameter of the torch holder.
19. Hang the cables to decrease the load applied on the carriage.
20. Do not bend the hi-flex track to a radius less than 0.75 m (2.5 ft).
21. Do not bend the semi-flex track to a radius less than 5 m (16 ft).
22. Use the rigid track only on flat surfaces.

23. At heights, protect the carriage and the track from falling. To do this, use chains (not included) to attach the leftmost and rightmost magnetic units of the hi-flex, semi-flex or rigid track to a stable structure. To protect the carriage, attach a chain to a carrying handle. Make sure that the chains are not loose.
24. Do not stay below the carriage or the track that is put at heights.
25. Use eye protection (helmet, shield, and screen), ear protection, gloves, and protective clothing. Do not use loose clothing.
26. Do not stop the carriage by hand. To stop, set the direction switch to 'O'.
27. Do the maintenance only after you unplug the carriage from the power source.
28. Repair only in a service center appointed by the seller.
29. If the carriage falls, is wet, or has any damage, stop the work and promptly send the carriage to the service center for check and repair.
30. Do not leave the carriage unattended during work.
31. If you are not going to use the carriage, remove it from the worksite and keep in a safe and dry place.

3. STARTUP AND OPERATION

3.1. Assembling the hi-flex, semi-flex, and rigid track

Attach magnetic units to the rail, and put it on the workpiece. Use the 4 mm or 5 mm hex wrench to attach more rails (1, Fig. 1). Then, set the levers of the magnetic units to 'I' (2). This will clamp the track to the surface.

When working in PC/2G welding position, put the track so that the teeth of the racks point down.

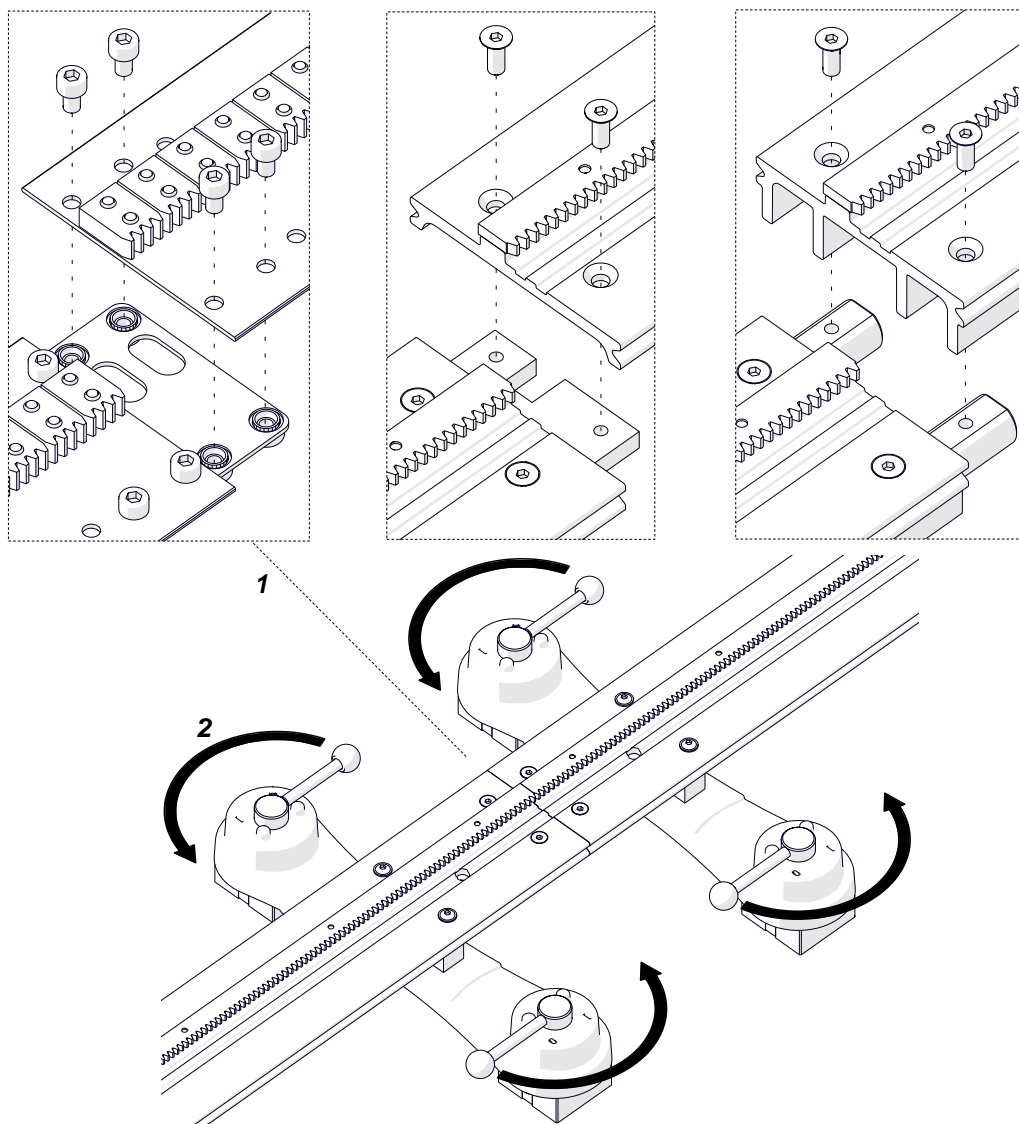

Fig. 1. Connecting the rails and clamping the magnetic units to the surface

If a semi-flex rail is put on a curve, before you attach more rails use the 4 mm hex wrench to loosen the screws of the connecting plates (1, Fig. 2) and of the racks (2). Next, attach the rails, clamp them with levers, and then tighten the connecting plates. Put the rack adjustment tool (not included) into the hole (3), and rotate the tool to the

left (4) to remove the gap (5) between the racks. Then, tighten the leftmost screw and the rightmost screw of each rack (2).

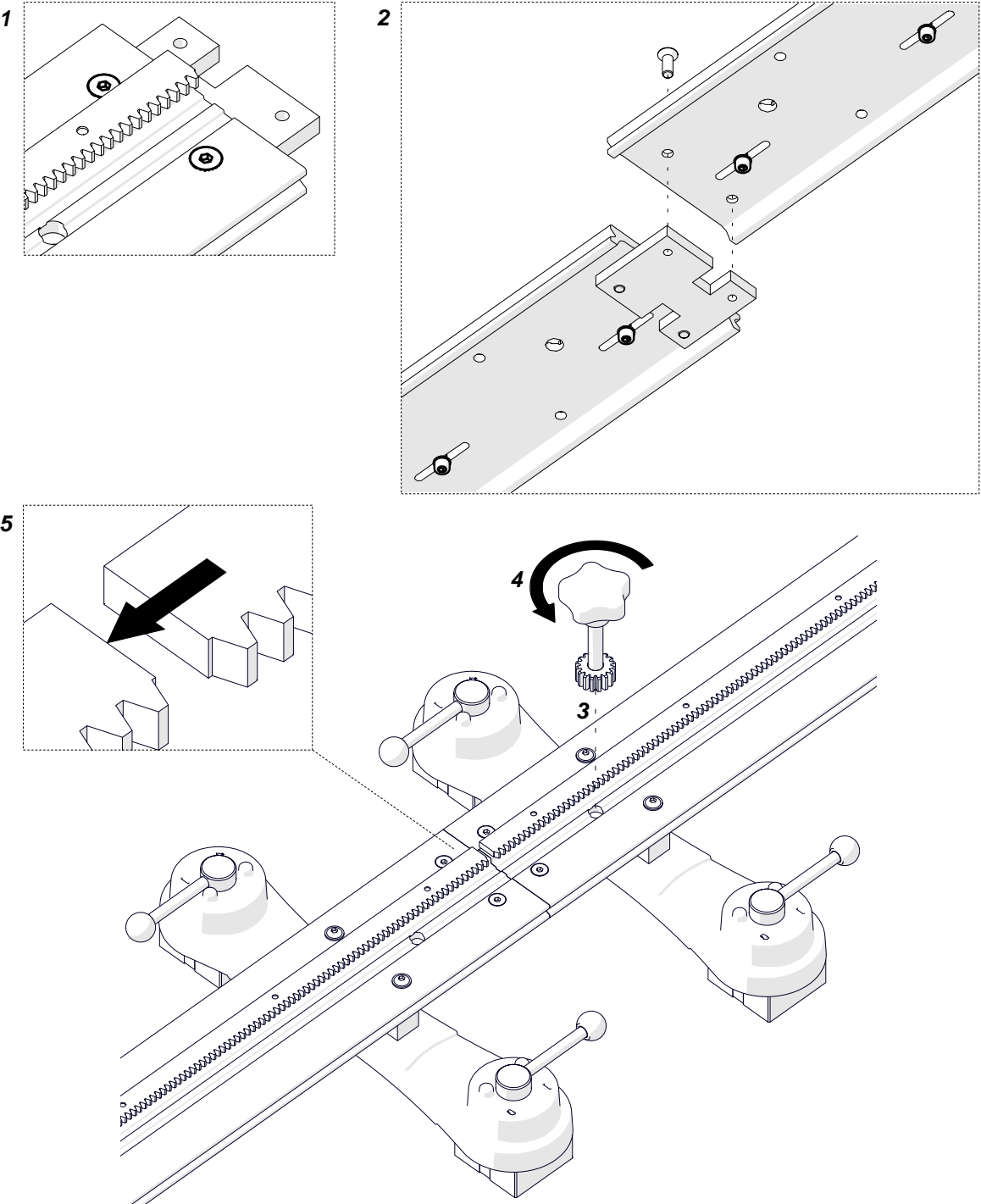

Fig. 2. Removing the gap between the racks of a semi-flex track

3.2. Assembling the ring track

Select the track that matches the outer diameter of the round workpiece. Use the 4 mm hex wrench to attach the supports to the rails (1, Fig. 3). Next, on all supports, retract the bolts (2, or screws) as much as possible.

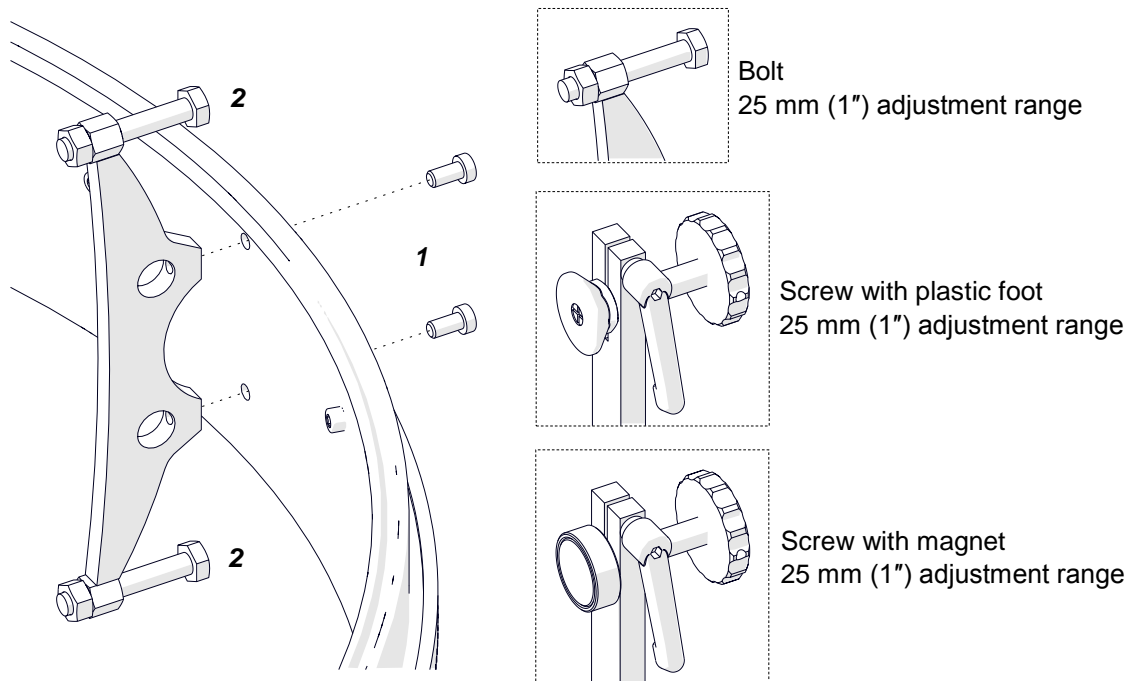

Fig. 3. Connecting the supports to the rails

Put the workpiece vertically, and then put the rails onto the workpiece so that the teeth of the racks point down. Next, for all rails, use the 12 mm hex wrench to set the hinge as shown in Fig. 4. Then, put the lock pin through the holes (1), and then rotate the wrench (2) to connect the rails.

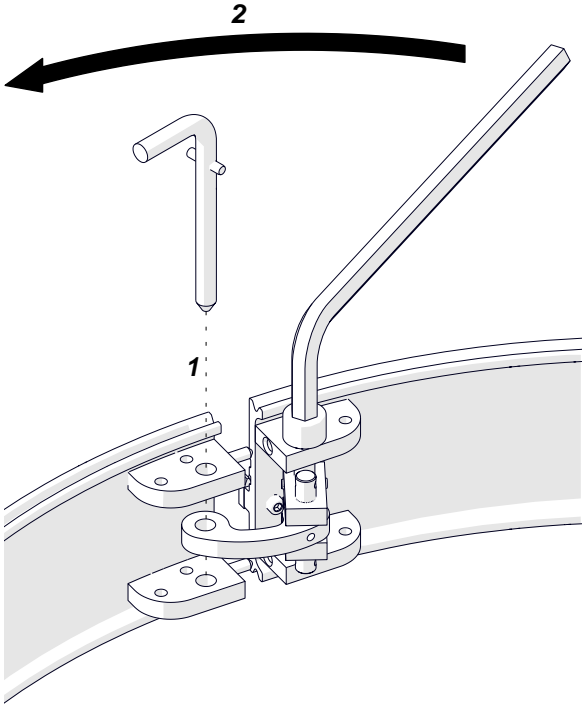

Fig. 4. Connecting the rails of the ring track

Use the 13 mm flat wrench to adjust the bolts (or the screws by hand) until they are in contact with the workpiece (1, Fig. 5). Adjust each support equally to make the track concentric to the workpiece. Lock the supports with the nuts (2) or levers.

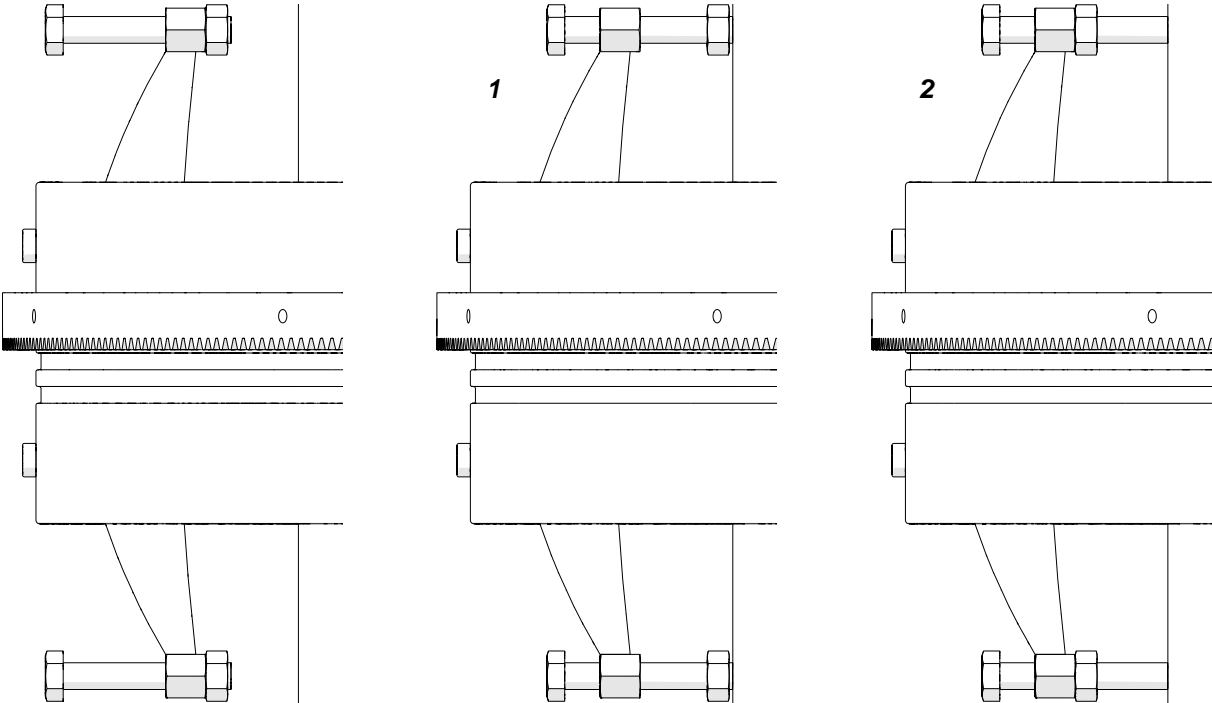

Fig. 5. Attaching the ring track to the workpiece

3.3. Positioning on a straight track

Set the power switch, arc ignition switch, oscillation switch, and direction switch to 'O'. Next, set the levers to OFF (1, Fig. 6), and then loosen the knob (2) fully to retract the gear (3). Then, put the carriage so that the mounting brackets are on the rail (4, 5).

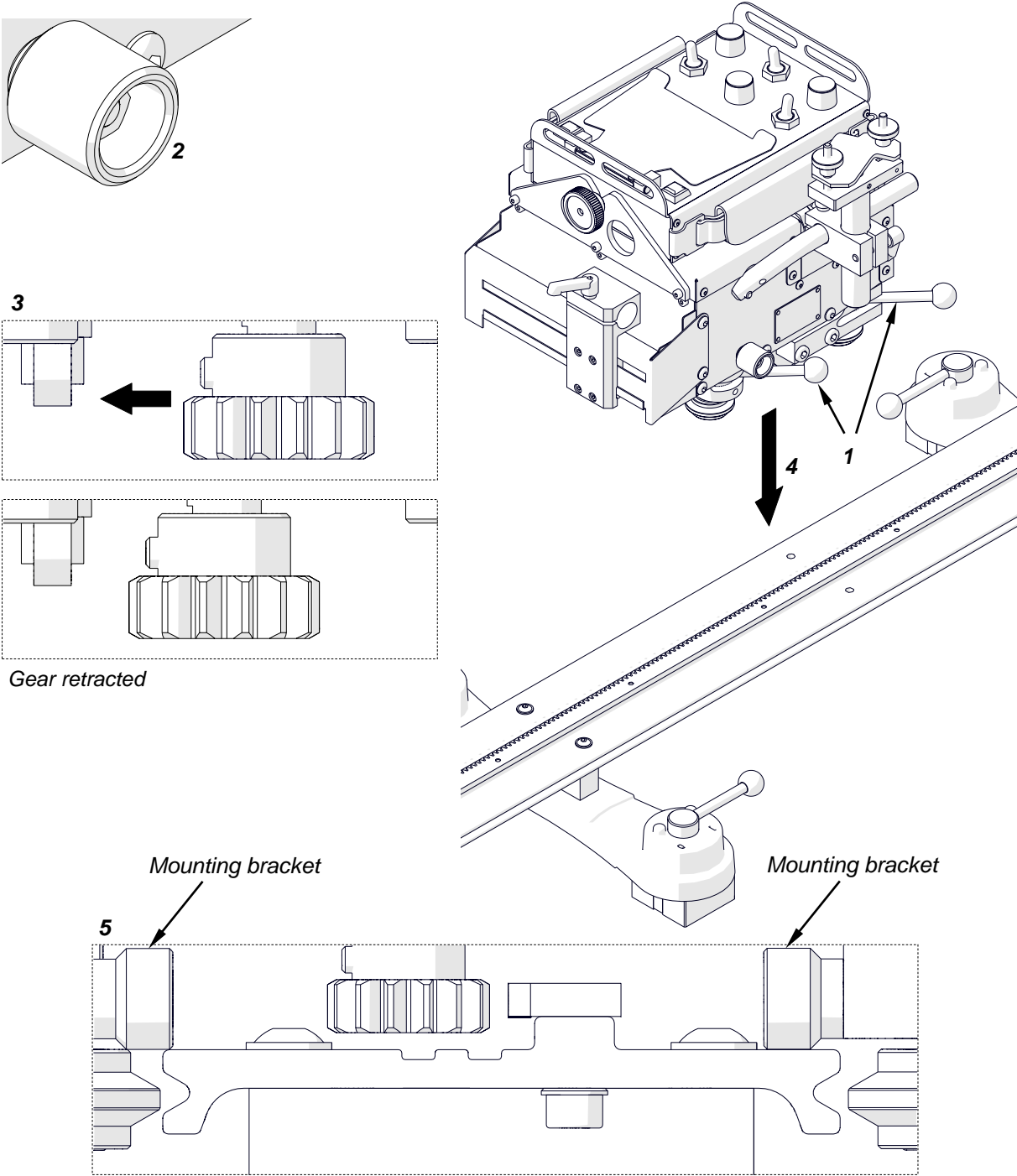

Fig. 6. Putting the carriage on a straight track

Set the levers to ON (1, Fig. 7) to put the rollers into the grooves (2). Tighten the knob (3) to engage the gear of the carriage with the rack of the rail (4). Keep a small backlash between the gear and the rack. Move the carriage slightly back and forth to make sure that there is a backlash.

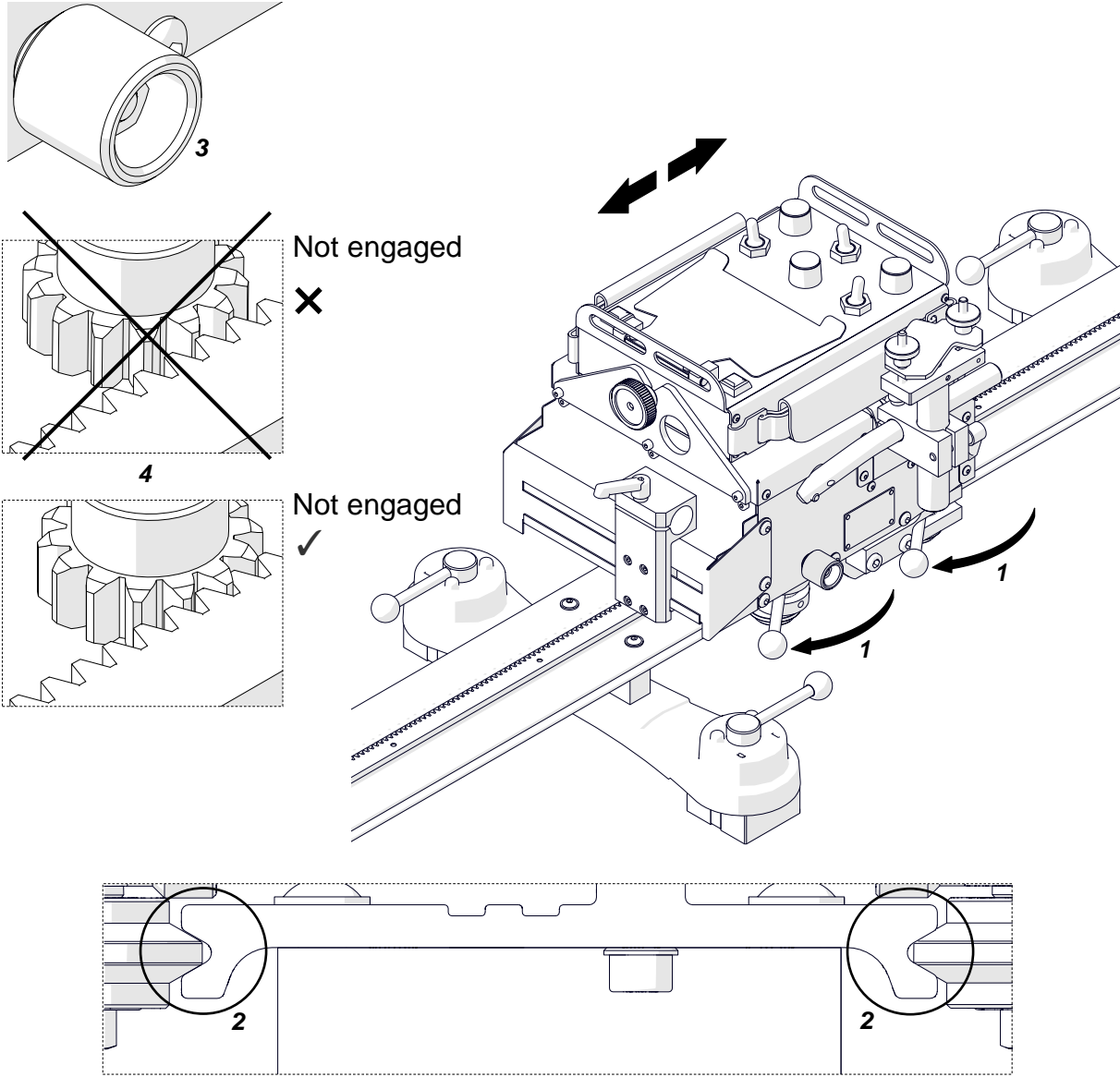

Fig. 7. Engaging the carriage with the track

3.4. Positioning on a curved track

Use the 6 mm hex wrench to loosen four screws (1, Fig. 8), and then put the carriage on the track. Rotate two roller brackets (2) to put the rollers into the grooves, and then set the levers to ON (3). Next, move the carriage back and forth to make sure that it moves smoothly. Then, tighten the screws (1) and use the knob (4) to engage the gear with the rack as described in "Positioning on a straight track".

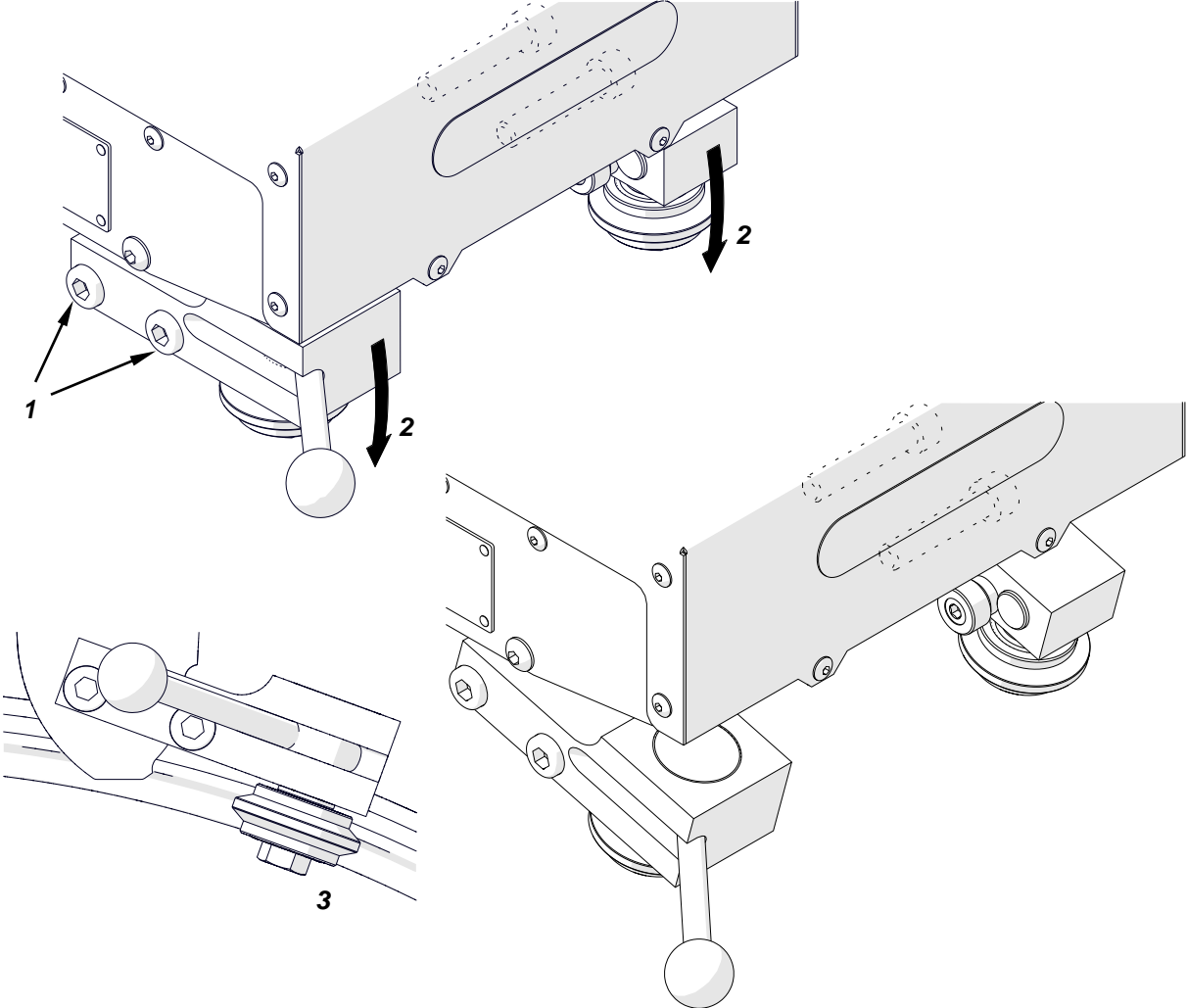

Fig. 8. Rotating the rollers for a curved track

3.5. Preparing and connecting

At heights, protect the carriage and the track from falling. To do this, use chains (not included) to attach the leftmost and rightmost magnetic units of the hi-flex, semi-flex or rigid track to a stable structure. To protect the carriage, attach a chain to a carrying handle. Make sure that the chains are not loose.

Connect the remote control to the carriage directly (1, Fig. 9), if the remote control will be put onto the carriage, or use the remote control cable (2). Then, use the power cable to connect the carriage to the power supply (3). Next, connect the power supply to the power source and put the torch and torch cables into the holders.

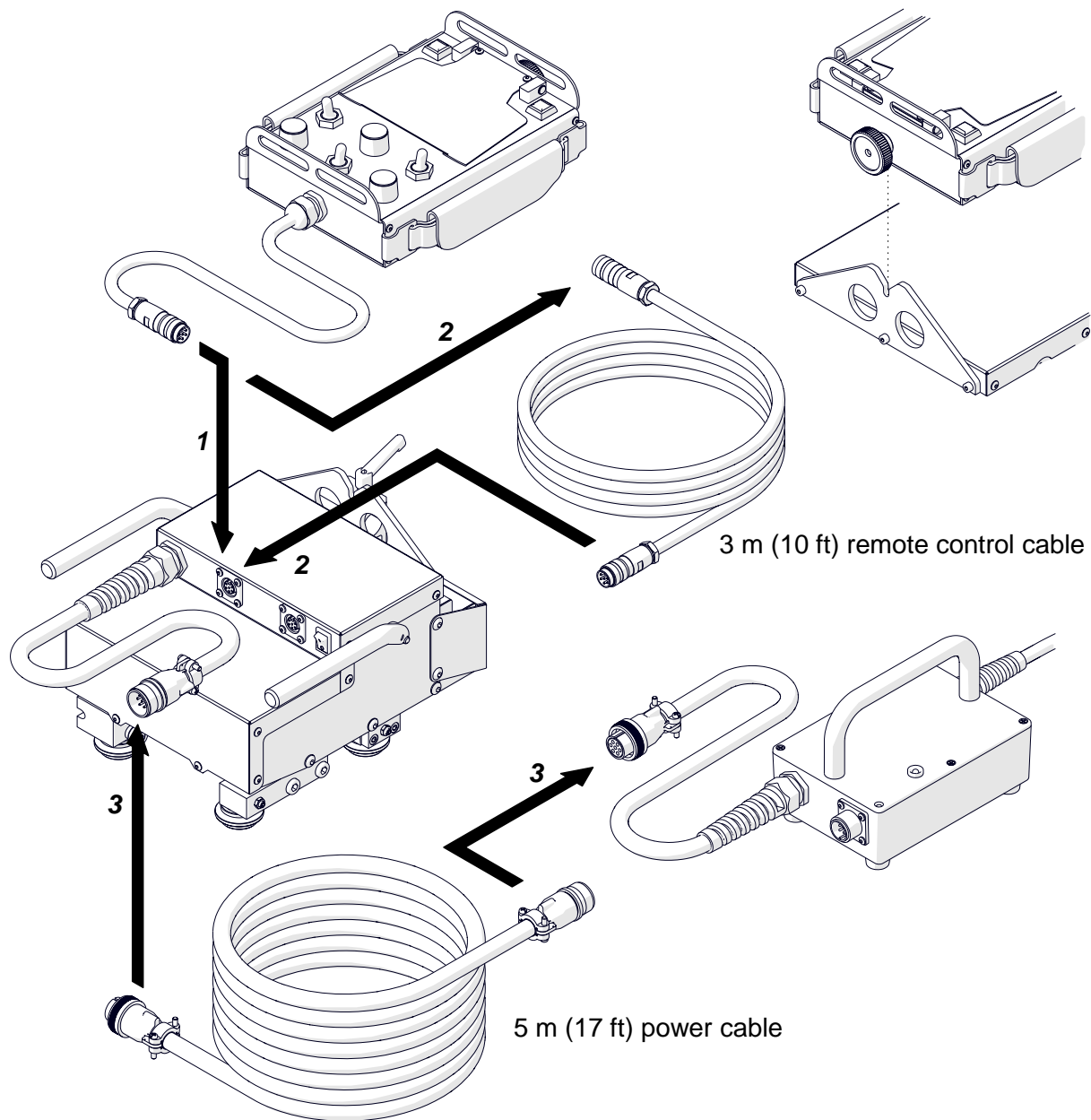

Fig. 9. Connecting the carriage

3.6. Connecting to the welding circuits

The carriage can control two torches by using the arc ignition cable plugged into the arc ignition socket. To do this, refer to the diagram from Fig. 10 and connect one blue-jacketed wire to one terminal of the welding circuit. Then, connect the other blue-jacketed wire to the other terminal of the same circuit. To control the second torch, connect the green-jacketed wires to the terminals of the second welding circuit.

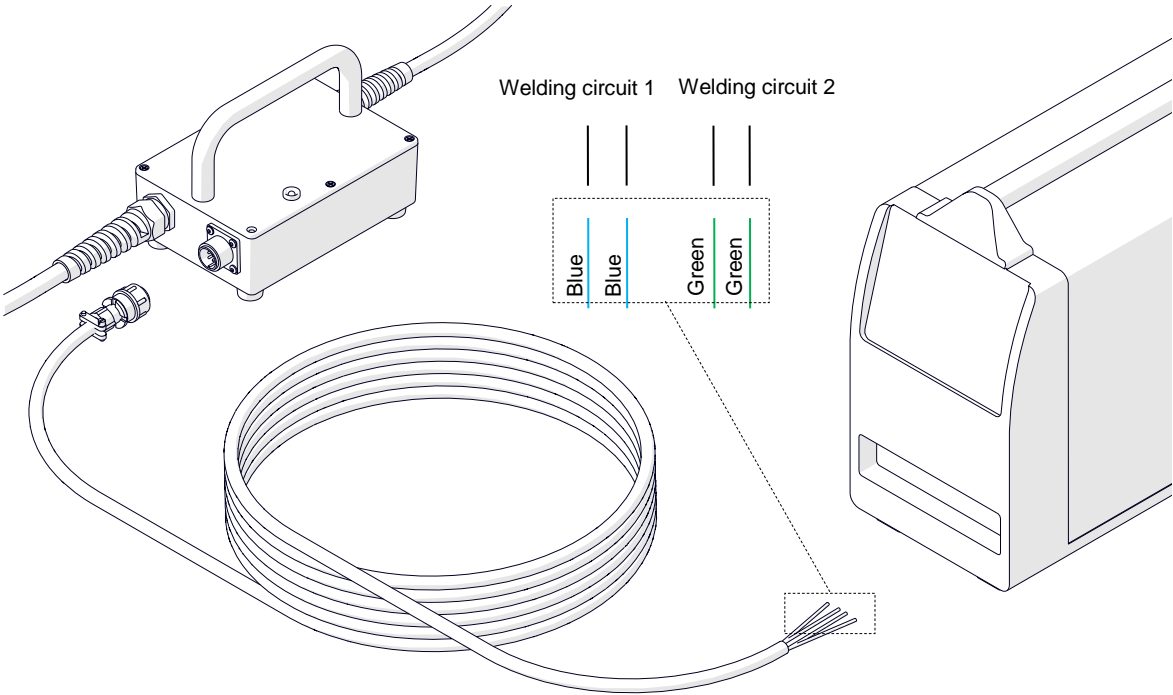

Fig. 10. Connecting the arc ignition cable to welding circuits

Make sure that the arc ignition cable is connected correctly. To do this, turn on the power of the carriage, and then set the arc ignition switch to TEST. This should enable the arc for a while.

3.7. Operating

Set the power switch to 'I' to turn on the carriage. To pause loading to check the firmware version, press and hold one of the navigation buttons. After you release the button, the control system loads and the main screen from Fig. 11 shows.

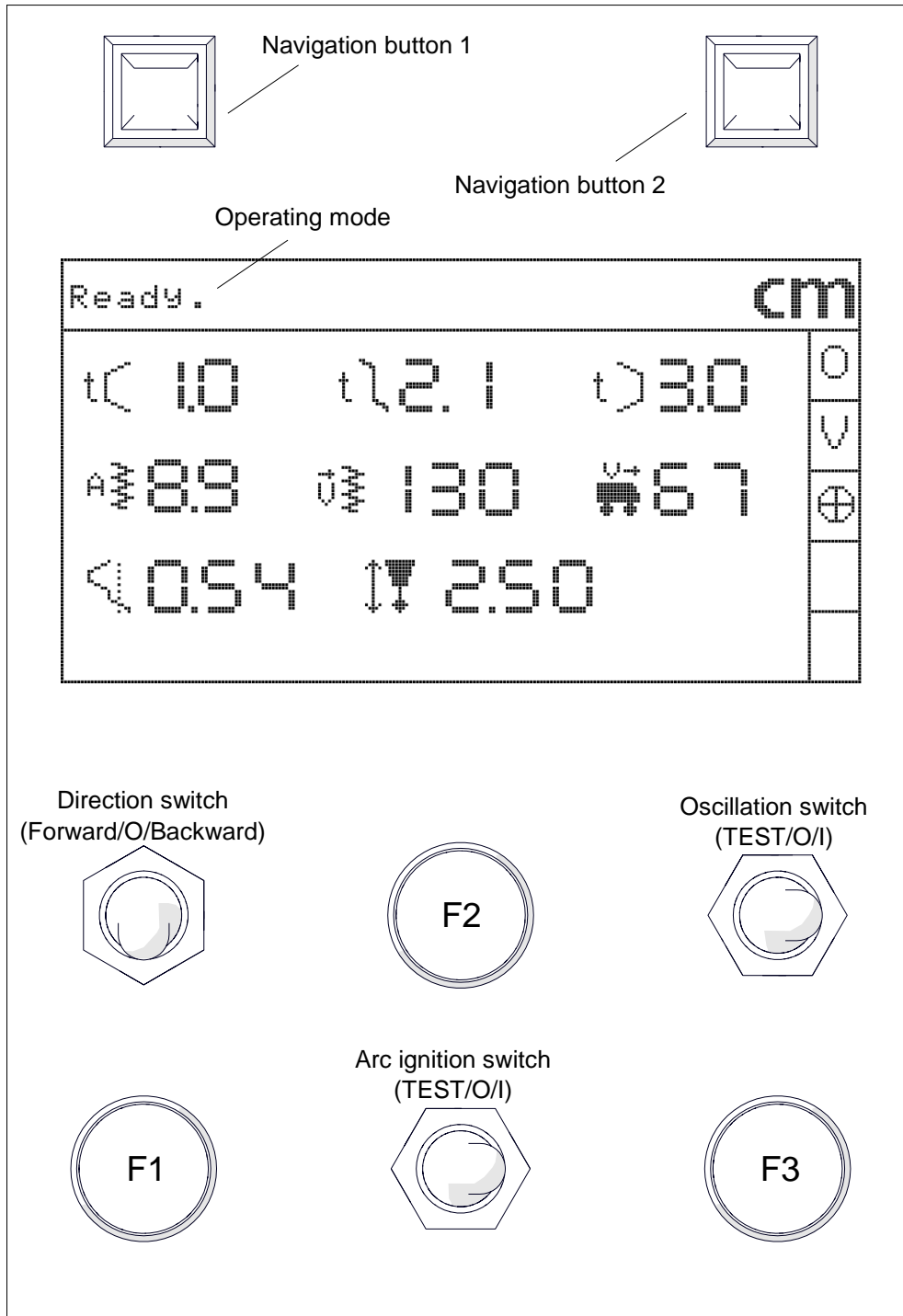





Fig. 11. Control panel with the main screen displayed



























Tab. 1 explains the symbols shown on the right of the main screen.

Tab. 1. Symbols of connected modules

Symbol	Description
	Linear oscillator.
	Motorized vertical slide (option).
	Tracking sensor (option).

Use the knobs to set the required parameters (Tab. 2). Rotate to the right to increase the value of the parameter. Rotate to the left to decrease the value.

Tab. 2. Parameters shown on the main screen

Parameter	Value	Description	Method of control
	0–5 s [step: 0.1]	Oscillation dwell time in left position.	Press and hold  and rotate 
	0–5 s [step: 0.1]	Oscillation dwell time in center position.	Press and hold  and rotate 
	0–5 s [step: 0.1]	Oscillation dwell time in right position.	Press and hold  and rotate 
	0.2–11.8 cm 0.1–4.5 in [step: 0.1/0.01]	Oscillation width.	Press and release  (activates ) and rotate 
	10–300 cm/min 5–120 in/min [step: 5/1]	Oscillation speed (when the vertical slide is not connected).	Rotate 
		Oscillation speed (when the vertical slide is connected).	Press and release  (activates ) and rotate 
	0–300 cm/min 0–120 in/min [step: 1/0.5]	Carriage speed.	Rotate 
		Travel the carriage with the maximum speed in the direction set by the direction switch.	Press and hold  when the arc ignition switch is set to 'O'
	From –9.9 to +9.9 cm From –3.9 to +3.9 in [step: 0.05/0.02]	Oscillation offset.	Rotate 
	From –2.5 to +2.5 cm From –1 to +1 in [step: 0.02/0.01]	Torch height (when the vertical slide is connected).	Rotate 
	cm inch	Unit of measure.	Rotate  in the correct setup screen.

To set the rest of the parameters, make sure that the direction switch is set to 'O'. Next, press and hold the two navigation buttons for three seconds to show the first setup screen (Fig. 12).

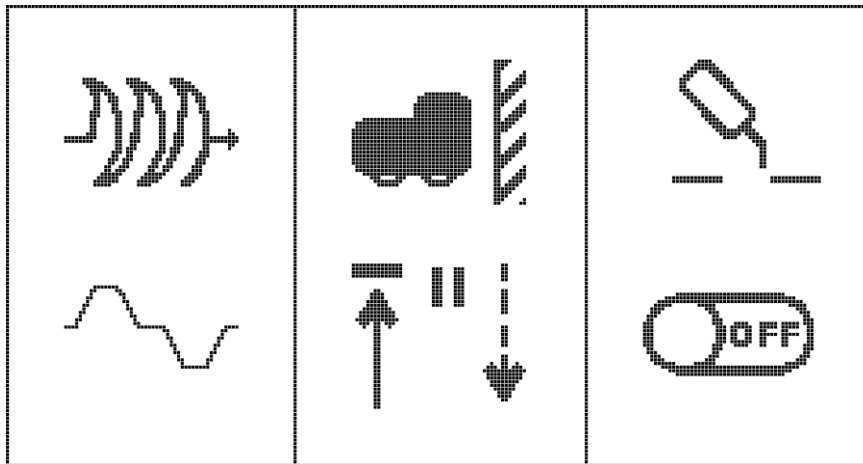

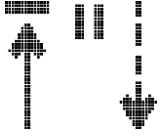
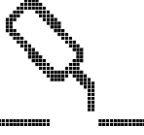















Fig. 12. First setup screen













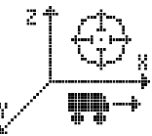

To go to the next setup screen, press the right navigation button. To go to the previous setup screen, press the left navigation button.









Use the knobs to set the required values of parameters (Tab. 3).

Tab. 3. Parameters shown on the setup screens

Parameter	Value	Description	Method of control
		Triangle. The carriage travels only during oscillation. During oscillation dwell time, the carriage stops to fill the crater.	Rotate (F1)
		Trapezoid. The carriage travels at all times, also during oscillation dwell time.	
		Square. The carriage travels only during oscillation dwell time in left and right position. During oscillation, the carriage stops. During oscillation dwell time in center position the carriage fills the crater.	
		Behavior when the limit switch is activated.	Rotate (F2)
		Stops the carriage and arc. To continue, set the direction switch to 'O'. This travels the carriage back by 10 mm (0.5 in) and removes the information symbol.	
		Stops the arc and travels the carriage back to the initial position from where the move started. To continue after the carriage reaches the initial position, set the direction switch to 'O'. This removes the information symbol.	

Parameter	Value	Description	Method of control
		Stops the carriage and arc. To continue, do 1 or 2. 1) Press F1, F2, or F3 to travel the carriage back to the initial position from where the move started. 2) Set the direction switch to 'O' to travel the carriage back by 10 mm (0.5 in).	
		Off. The carriage welds continuously.	Rotate 
		On. Activates parameters of stitch welding. Do not set them to zero if you want to weld continuously. Instead, set stitch welding to OFF.	
	0–100 cm 0–40 in [step: 0.1]	Weld length (parameter available only when the stitch welding is set to ON).	Rotate 
OR			
	0–100 cm 0–40 in [step: 0.1]	Space before welding.	Press, hold, and rotate 
	0–100 cm 0–40 in [step: 0.1]	Space between welds (only for stitch welding).	Rotate 
	0–999 cm 0–400 in ∞ [step: 1/0.5]	Total length. After reaching the total length the carriage acts as if the limit switch is activated.	Rotate or press 
	0–10 cm 0–4 in [step: 0.1]	Backweld length (parameter available only when the stitch welding is set to ON).	Rotate 
OR			
	0–5 s [step: 0.1]	Crater fill time before welding.	Press, hold, and rotate 

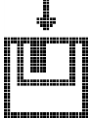
Parameter	Value	Description	Method of control
	0–5 s [step: 0.1]	Crater fill time at weld end (parameter available only when the stitch welding is set to ON).	Rotate (F2)
OR			
	0–5 s [step: 0.1]	Crater fill time after welding.	Press, hold, and rotate (F2)
		Off. Welding source decreases the current of the arc while filling the crater. Set the crater fill time higher or equal to the time of the current lowering that is set at the welding source.	Rotate (F3)
		On. Welding source uses full current while filling the crater.	
		Automatic tracking of the welding seam (control of parameter possible only when the tracking sensor is used). When Z, YZ (require the motorized vertical slide), or Y is set, you can adjust the initial torch position from the main screen with F1.	Rotate (F1)
		Off. The welding seam will not be tracked automatically. However, you can adjust the torch position in the Y axis from the main screen during welding (also in the Z axis when the motorized vertical slide is used). Operating mode: TRK : OFF.	
		Automatic tracking in the Y axis only. Operating mode: TRK : Y.	
		Automatic tracking in the Z axis only. Operating mode: TRK : Z.	
		Automatic tracking in the Y and Z axis. Operating mode: TRK : YZ.	
OR			
		Sensitivity of the tracking system.	Press, hold, and rotate (F1)
		Normal.	
		Low. The torch adjusts slower to the welding seam.	
		High. The torch adjusts faster to the welding seam.	
	cm inch	Unit of measure. Metric or imperial.	Rotate (F3)

Parameter	Value	Description	Method of control
	1-10	Loads the configuration saved under the chosen program number. No. 1 is factory default.	Rotate 
	Default, Filler, Linear, Root, Segment, Top	Sample name to describe the loaded configuration.	Press, hold, and rotate 
	1-10	New configuration.	Rotate 
		Copies the loaded configuration to the chosen number of the new configuration.	Press 
		Saves changes to the loaded configuration.	Press 

To go back to the main screen, press and hold the two navigation buttons for three seconds.

To control the torch through the carriage, set the arc ignition switch to 'I'.



If the arc ignition switch is set to 'I', the torch starts welding promptly after you select a travel direction.

Use the direction switch to select a direction of travel. Then, the travel starts with the set parameters. Then, the status changes from **Ready** to **Running**. You can adjust the parameters from the main screen at any time with the knobs. You can adjust the parameters from the setup screens only when the carriage is stopped.

To stop the travel, set the direction switch to 'O'.

After the work is finished, use the power switch to turn off the carriage. Then, unplug the carriage from the power source.

3.8. Adjusting the pressure of rollers

If the resistance during the travel is too little or too much, loosen the knob (1, Fig. 13). At the opposite side of the carriage, use the 13 mm and 8 mm flat wrenches to loosen the bolts (2) and nuts (3). Next, use the 2.5 mm hex wrench to adjust the screws (4), and then tighten the bolts (2).

Move the carriage along the track. If the resistance is still incorrect, repeat the above steps.

If the carriage moves smoothly, use the 2.5 mm hex wrench to prevent rotation of each screw (4). Then, use the 8 mm flat wrench to tighten the nuts (3).

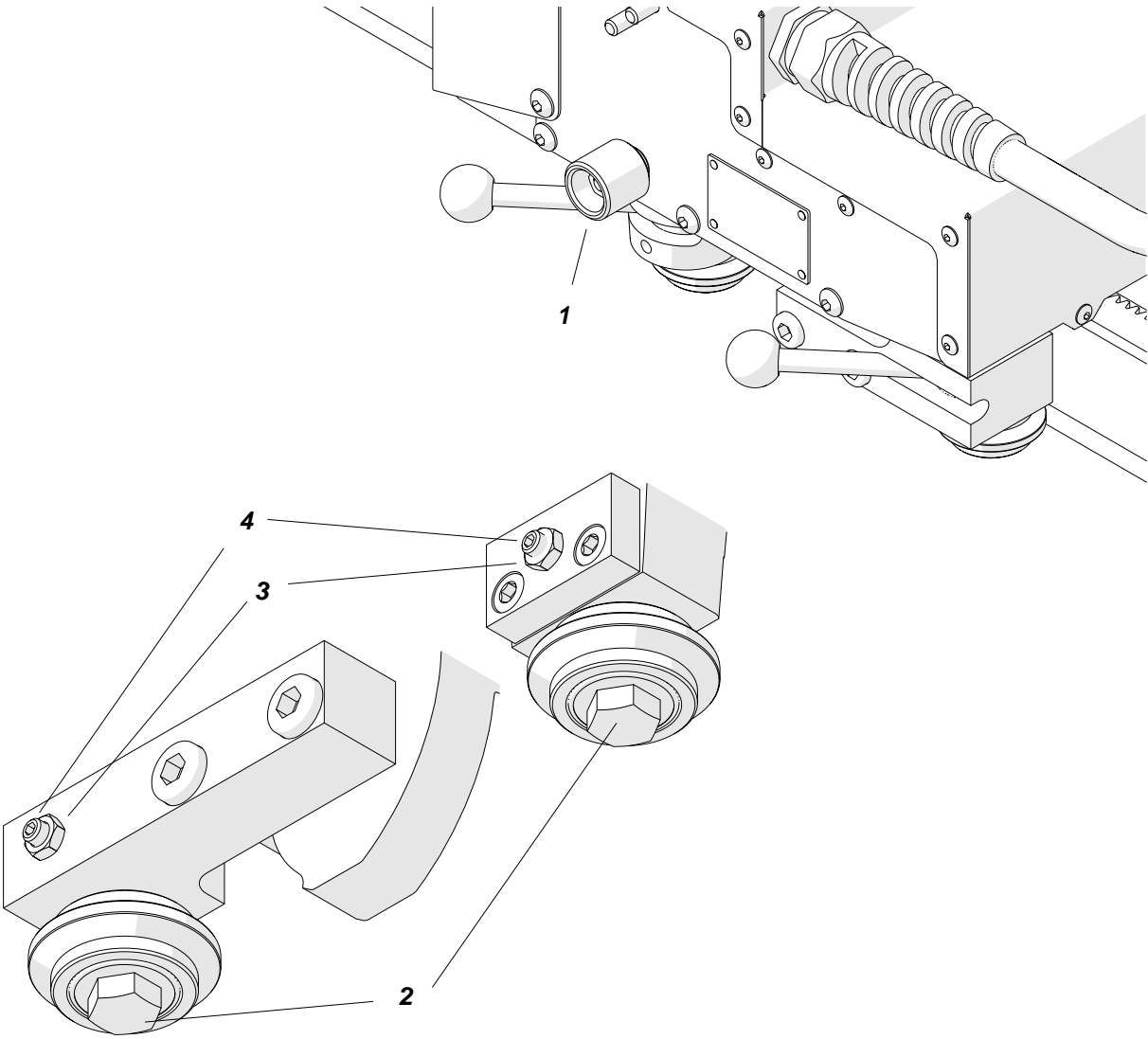

Fig. 13. Adjusting the pressure of rollers

3.9. Adapting for seam tracking (option)

Remove all parts from the rod holder (Fig. 14) and install the motorized vertical slide. Then, assemble the attachment as shown.

To use a different sensor tip, use the 2 mm hex wrench and remove the installed rod. Next, install a rod with fork tip. You can also use the 1.5 mm hex wrench to attach one of three tips to a separate rod, and then install the rod into the sensor.

Make sure that the carriage travels to the direction shown in Fig. 14 to be able to track the seam correctly.

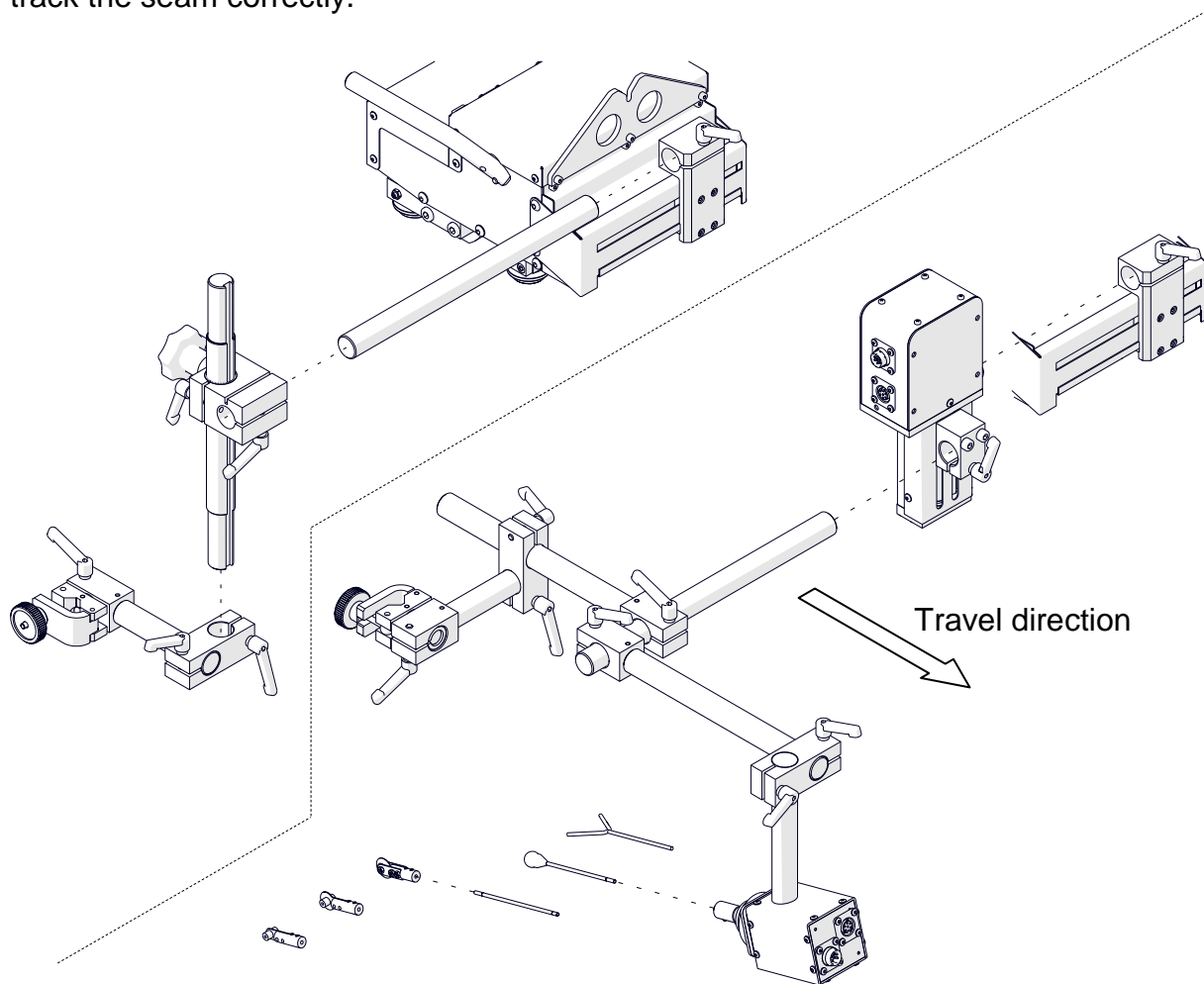

Fig. 14. Changing the basic configuration to seam tracking configuration

Use the 0.75 m (2.5 ft) signal cable to connect the motorized vertical slide to the carriage (Fig. 15). Then, use the 0.5 m (1.5 ft) signal cable to connect the sensor to the vertical slide. If the vertical slide is not used, connect the sensor to the carriage with the 1 m (3 ft) signal cable.

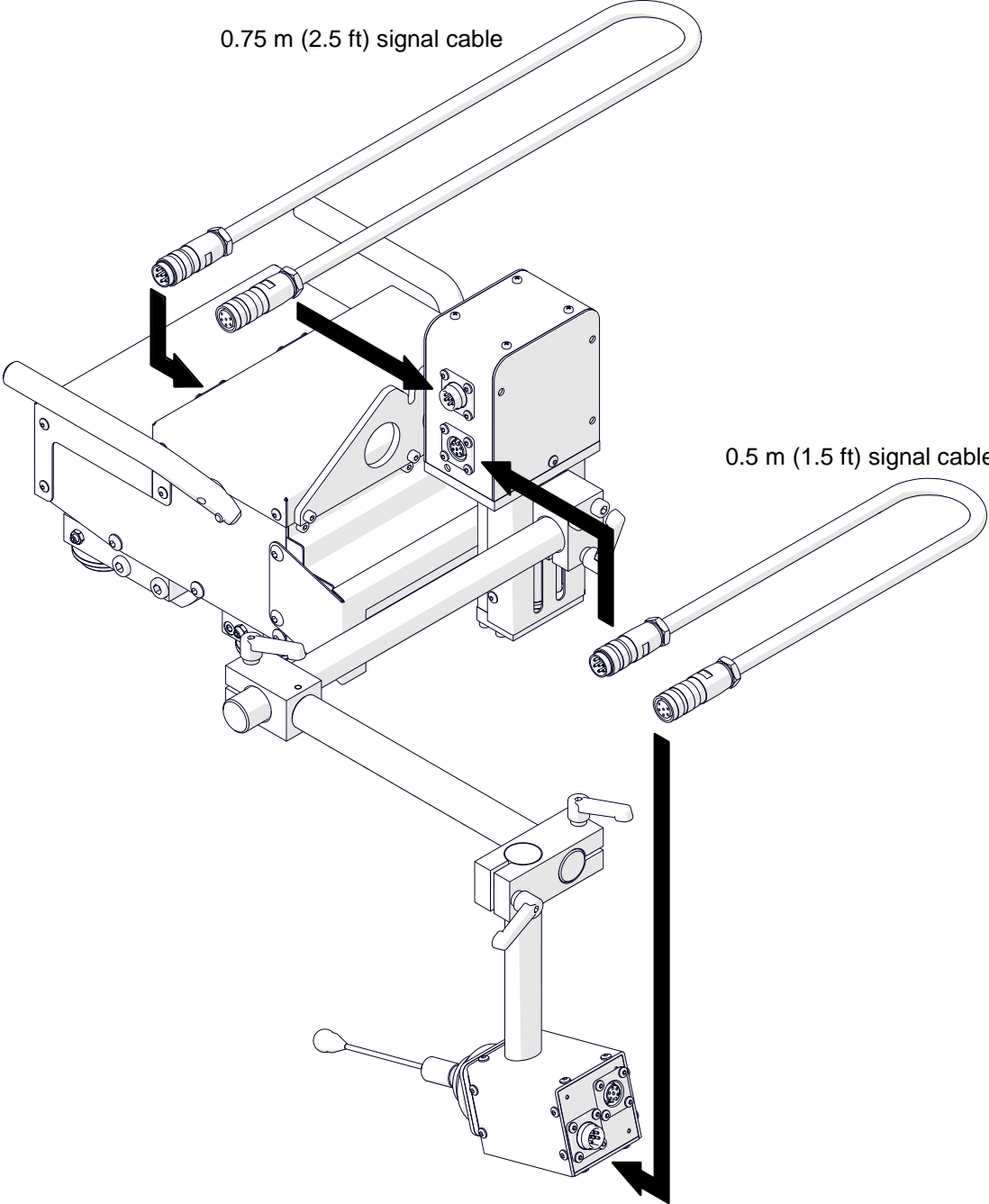

Fig. 15. Connecting the tracking sensor to the carriage

Install the torch into the torch holder. Then, tilt the rod of the sensor against the workpiece so that there is tension in the rod. Next, put the tip in the welding seam (Fig. 16).

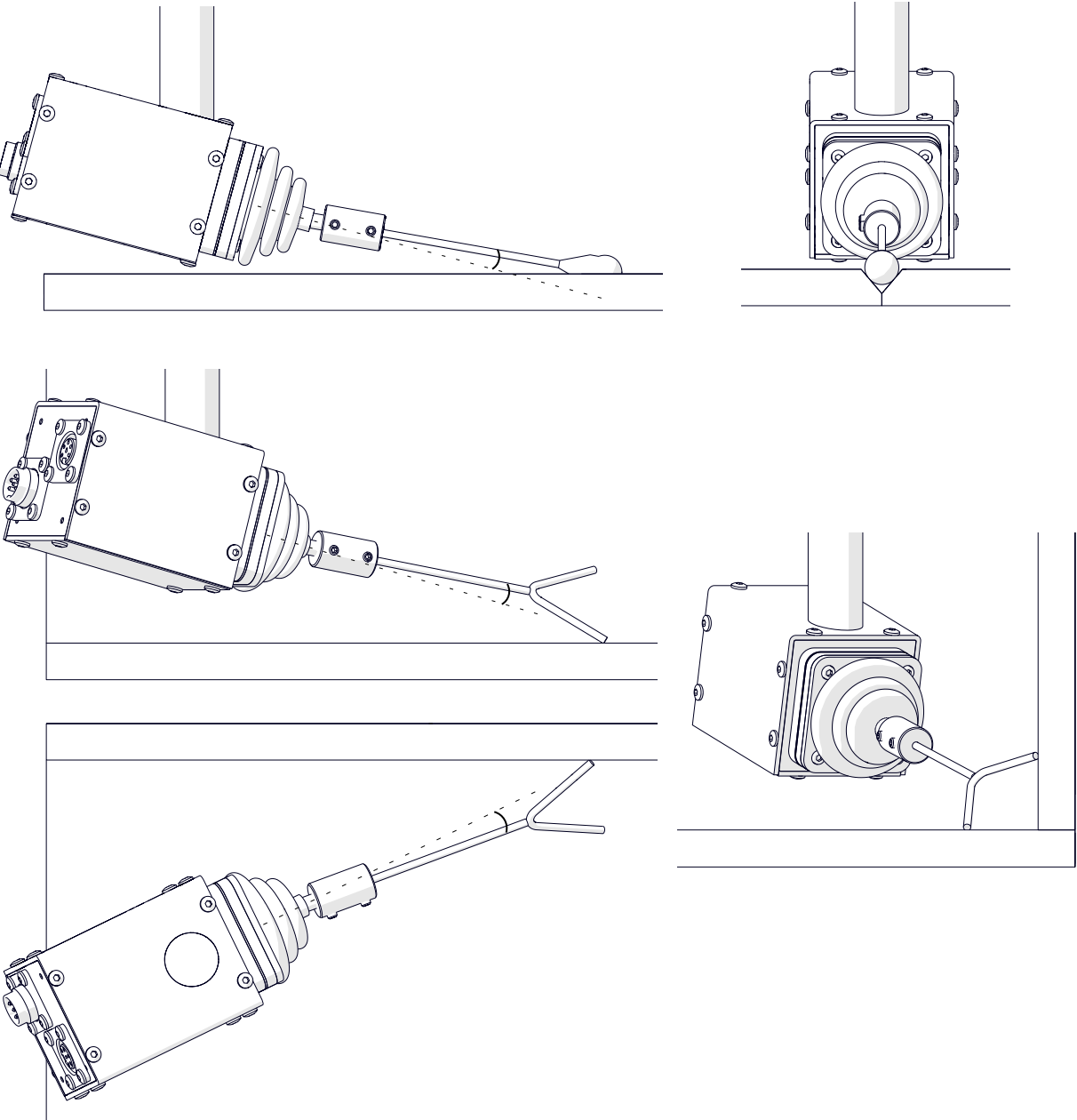

Fig. 16. Setting the tracking sensor correctly in the welding seam

Fig. 17 shows how the tracking system works. When the tip of the sensor moves in the seam, the system senses any small change in position of the seam. Then, the oscillator, the vertical slide, and the torch, are moved to maintain the correct position above the seam.

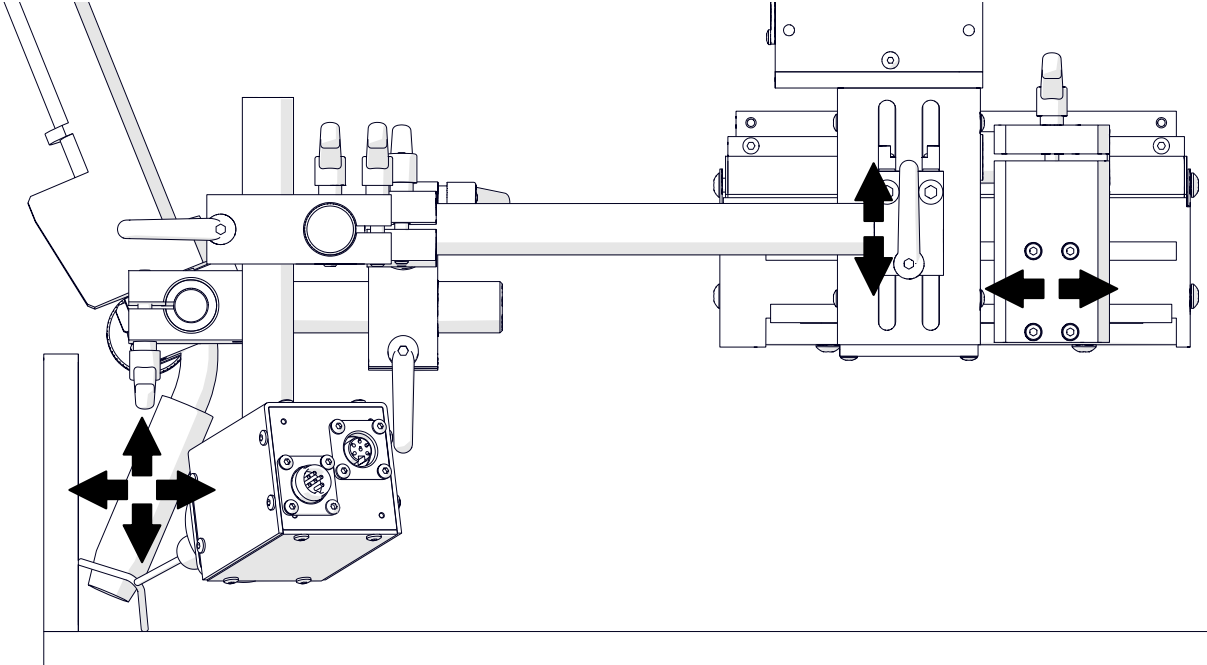

Fig. 17. Torch moves with small changes in position of the seam

3.10. Troubleshooting

Message	Problem	Solution
INFO #1	Limit switch activated during travel.	Set the direction switch to 'O'.
	Limit switch active when powering.	Loosen the drive clutch knob to disengage the gear. Move the carriage until the limit switch is released.
WARNING #1	Direction switch not set to 'O' when powering.	Set the direction switch to 'O'.
WARNING #3	Arc ignition switch set to TEST when powering.	Set the arc ignition switch to 'O'.
WARNING #4	Oscillation switch set to TEST when powering.	Set the oscillation switch to 'O'.
WARNING #5	Sensor tip fell out of the weld groove when tracking and arcing.	Set the direction switch to 'O'. Make sure that the tension in the rod of the sensor is correct. Use the correct tip for the application.
ERROR #1	Controller failure or no communication.	Contact service center for check and repair.
ERROR #2	Motor overload.	Adjust the position of the cables so that they do not block the carriage. Remove obstacles that block the carriage or the drive gear.

4. MAINTENANCE

Each day:

1. Clean the gear of the carriage and the rack of each rail.
2. Clean the rollers. Make sure that the rollers rotate freely.
3. Clean the torch nozzle and replace if damaged.

Each month:

1. Make sure that the knobs and the switches work as intended. Replace if they are loose or damaged.
2. Examine cables and cords, and replace if damaged.
3. Tighten screws if loose.

5. ACCESSORIES

5.1. Seam tracking attachment

Allows the carriage to track the welding seam.

Part number:
CZJ-0523-07-00-00-1

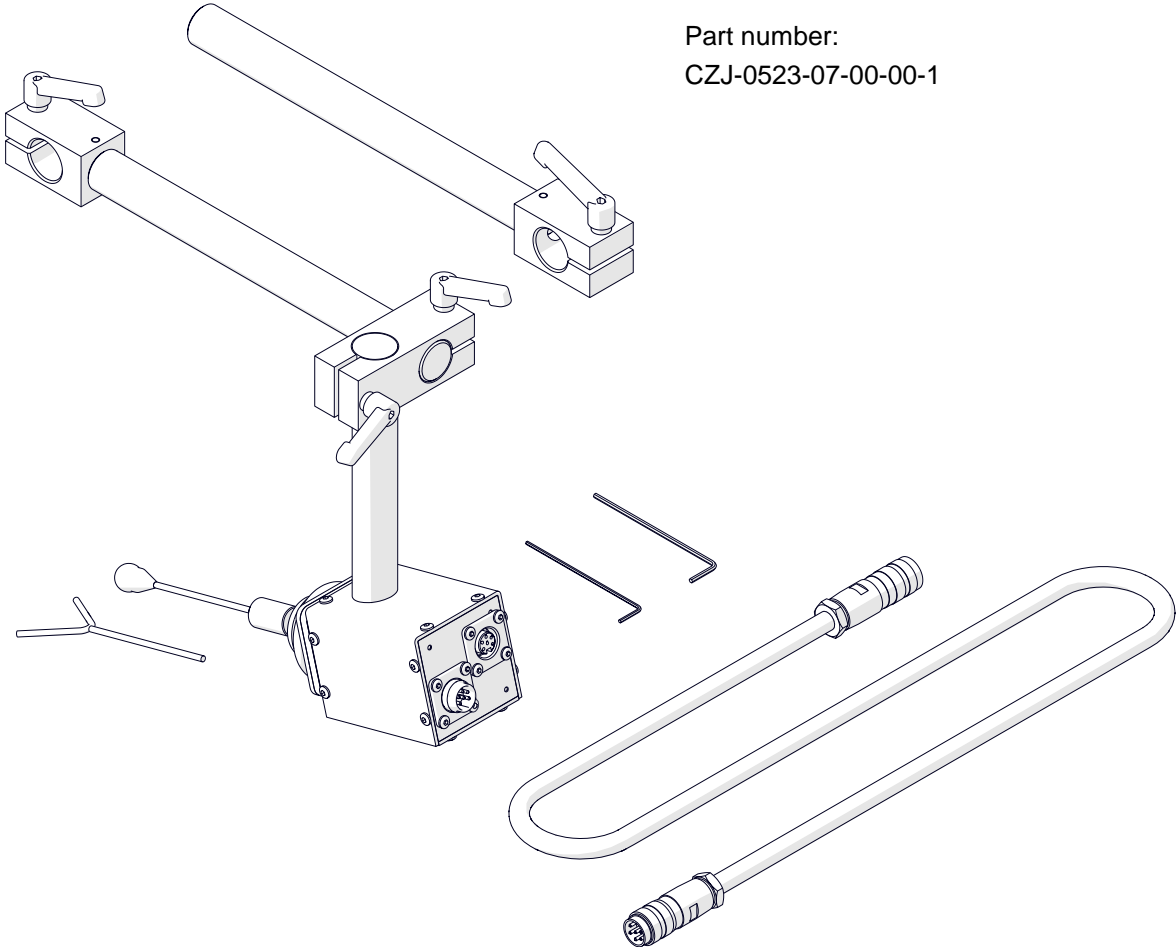

5.2. Tracking sensor tips

Allow seam tracking in various applications.

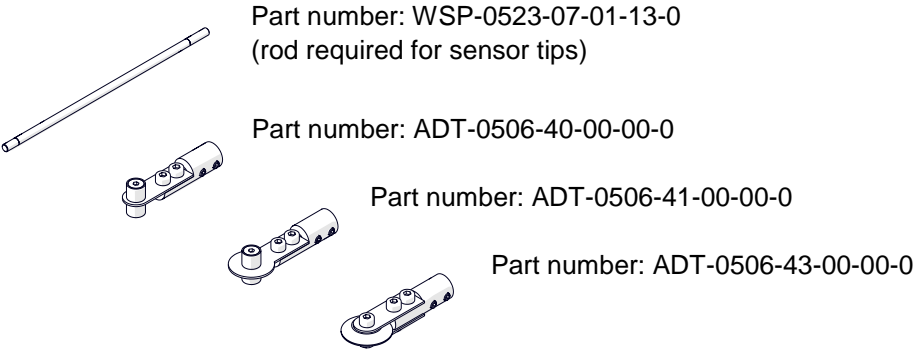

5.3. Motorized vertical slide

Allows the vertical position of the torch to be controlled.

Part number:
OSK-0523-06-00-00-1

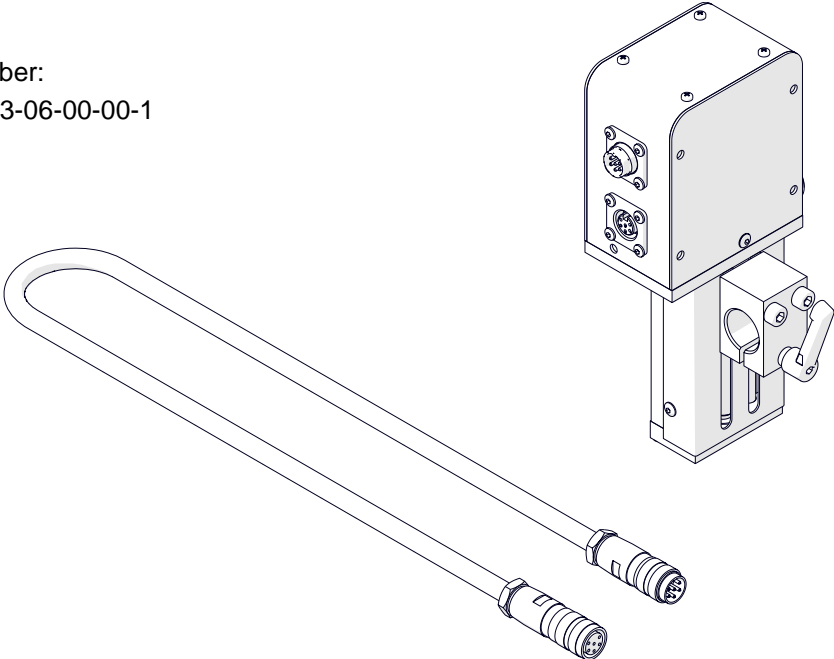

5.4. 0.5 m (1.5 ft) signal cable

Required for connecting the motorized vertical slide to the tracking sensor.

Part number:
PWD-0523-07-01-09-0

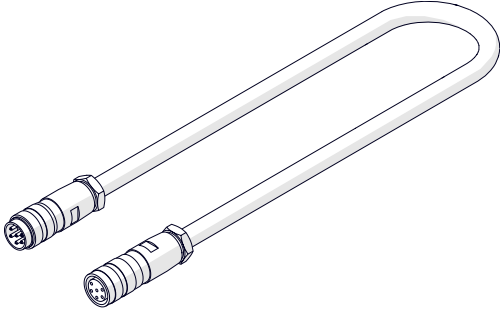

5.5. Hi-flex track

Allows guiding the carriage along a curve. The length of a single rail is 1.52 m (5 ft). The minimum bend radius is 0.75 m (2.5 ft). Use with 8 magnetic units or 8 narrow magnetic units. If you need to use more units, use narrow magnetic units.

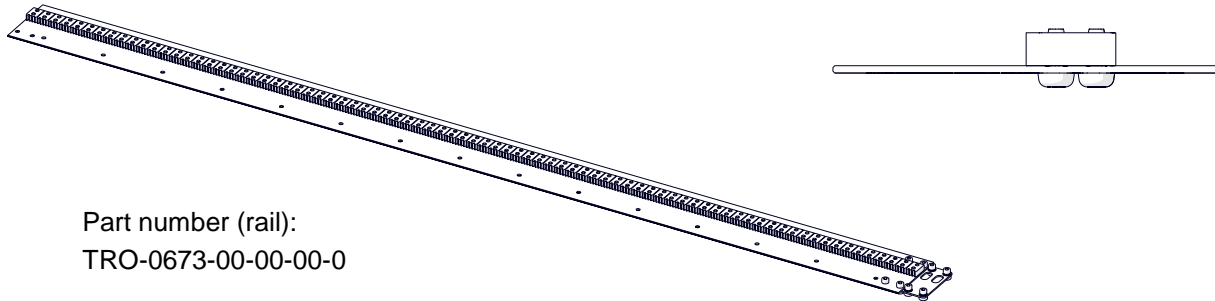

Part number (rail):
TRO-0673-00-00-00-0

Part number (rollers for hi-flex track):
ZSP-0673-07-00-00-0

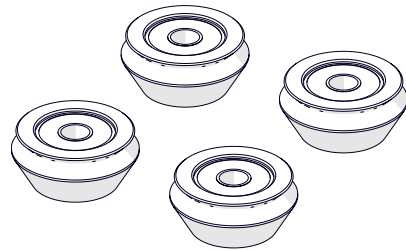

Use the 13 mm flat wrench to remove the standard rollers and install the rollers for hi-flex track.

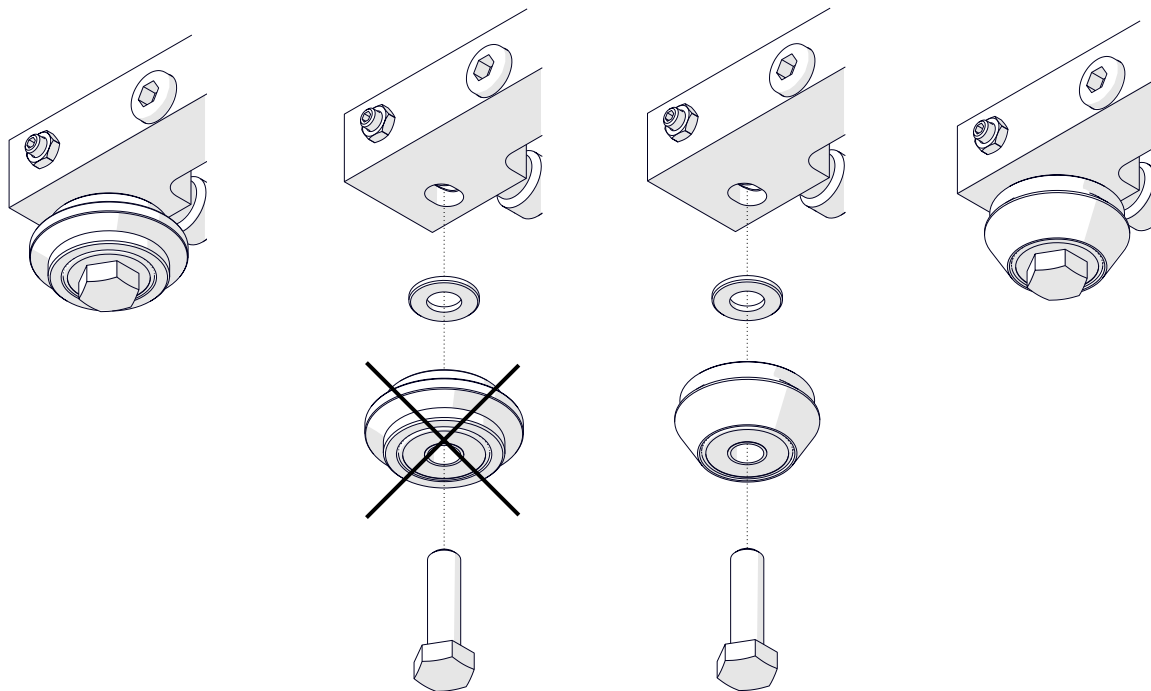

5.6. Semi-flex track

Allows guiding the carriage along a curve. The length of a single rail is 2 m (6.5 ft). The minimum bend radius is 5 m (16.5 ft).

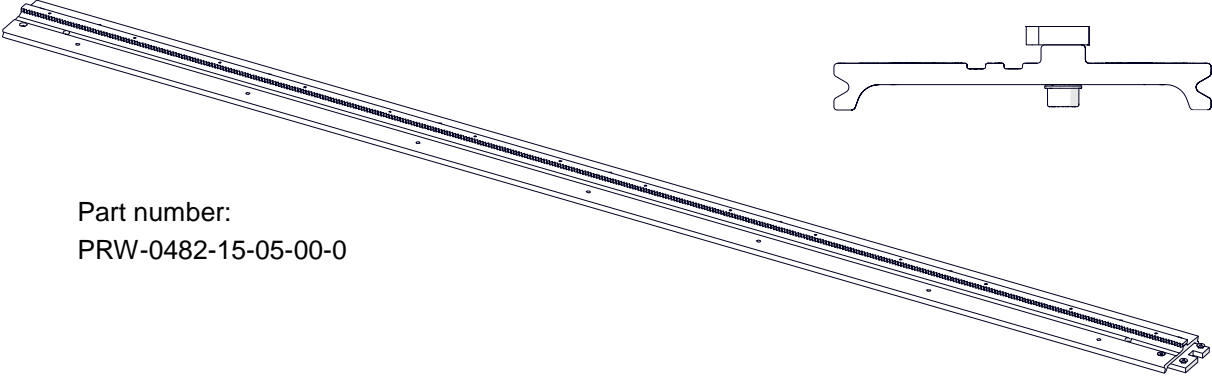

Part number:
PRW-0482-15-05-00-0

5.7. Rigid track

Allows guiding the carriage along a straight line. The length of a single rail is 2 m (6.5 ft).

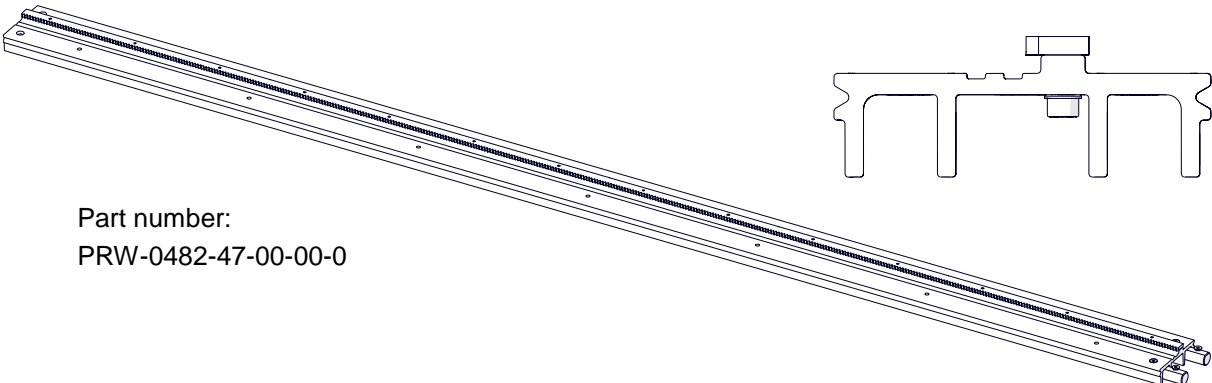

Part number:
PRW-0482-47-00-00-0

5.8. Rack adjustment tool

Removes the clearance between the racks of two semi-flex rails that are put on a curve.

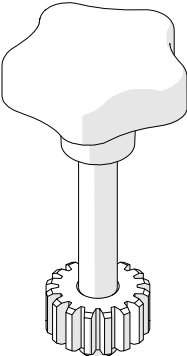

Part number:
PKT-0341-13-00-00-0

5.9. Contact block

Protects the carriage from falling off a track with open ends. When the carriage comes into contact with the block, the limit switch is activated. Use two blocks to close the track and limit the travel path to a section. To install the contact block on a semi-flex or rigid track, use the 6 mm hex wrench.

Part number:
ZDR-0523-76-00-00-0

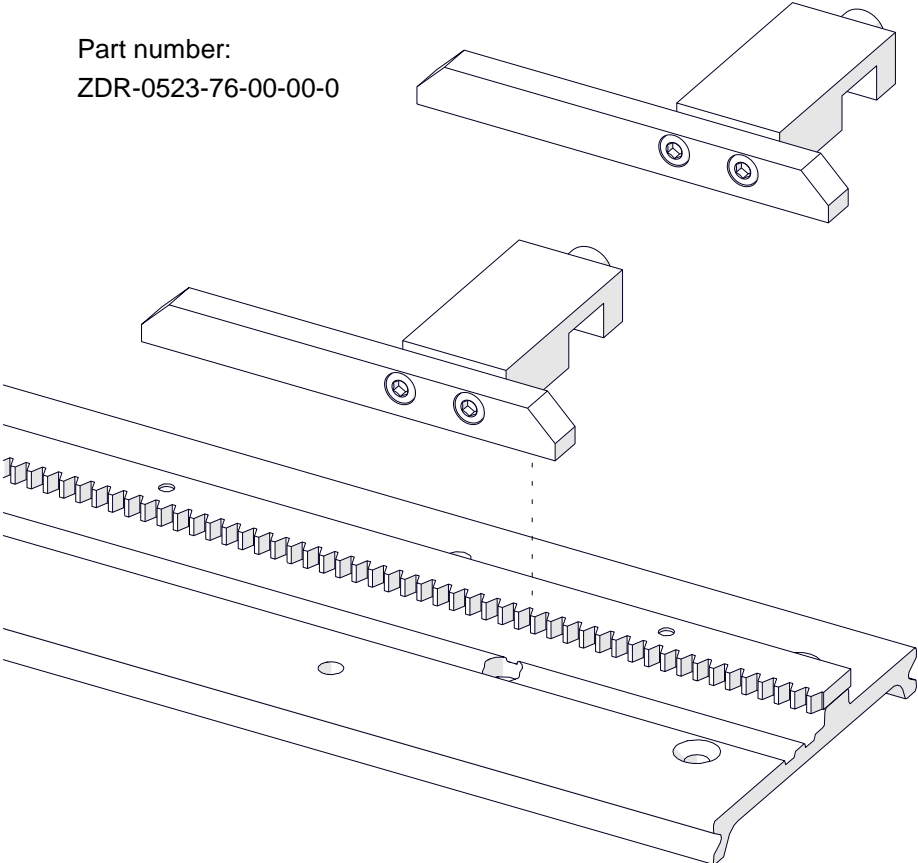

5.10. Magnetic units

5.10.1. Magnetic unit

Allows clamping a hi-flex, semi-flex, or rigid track to ferromagnetic surfaces.

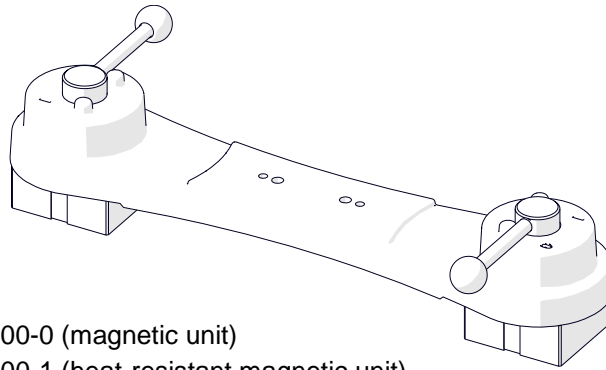

Part number:
 ZSP-0475-44-00-00-0 (magnetic unit)
 ZSP-0475-44-00-00-1 (heat-resistant magnetic unit)

Part number (bracket for
 hi-flex and semi-flex track):
 DYS-0482-19-00-00-0

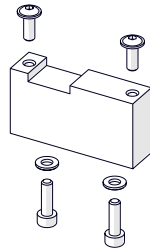

Part number (bracket for rigid
 track):
 DYS-0482-21-00-00-0

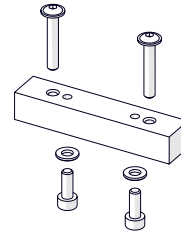

Holding force on a 5 mm (0.2") thick surface	Temperature	
	Magnetic unit	Heat-resistant magnetic unit
100% (1200 N)	20°C (68°F)	20°C (68°F)
75% (900 N)	80°C (176°F)	160°C (320°F)
50% (600 N)	120°C (248°F)	200°C (392°F)

Use the 4 mm hex wrench to attach the unit to the tracks as shown in the figures.

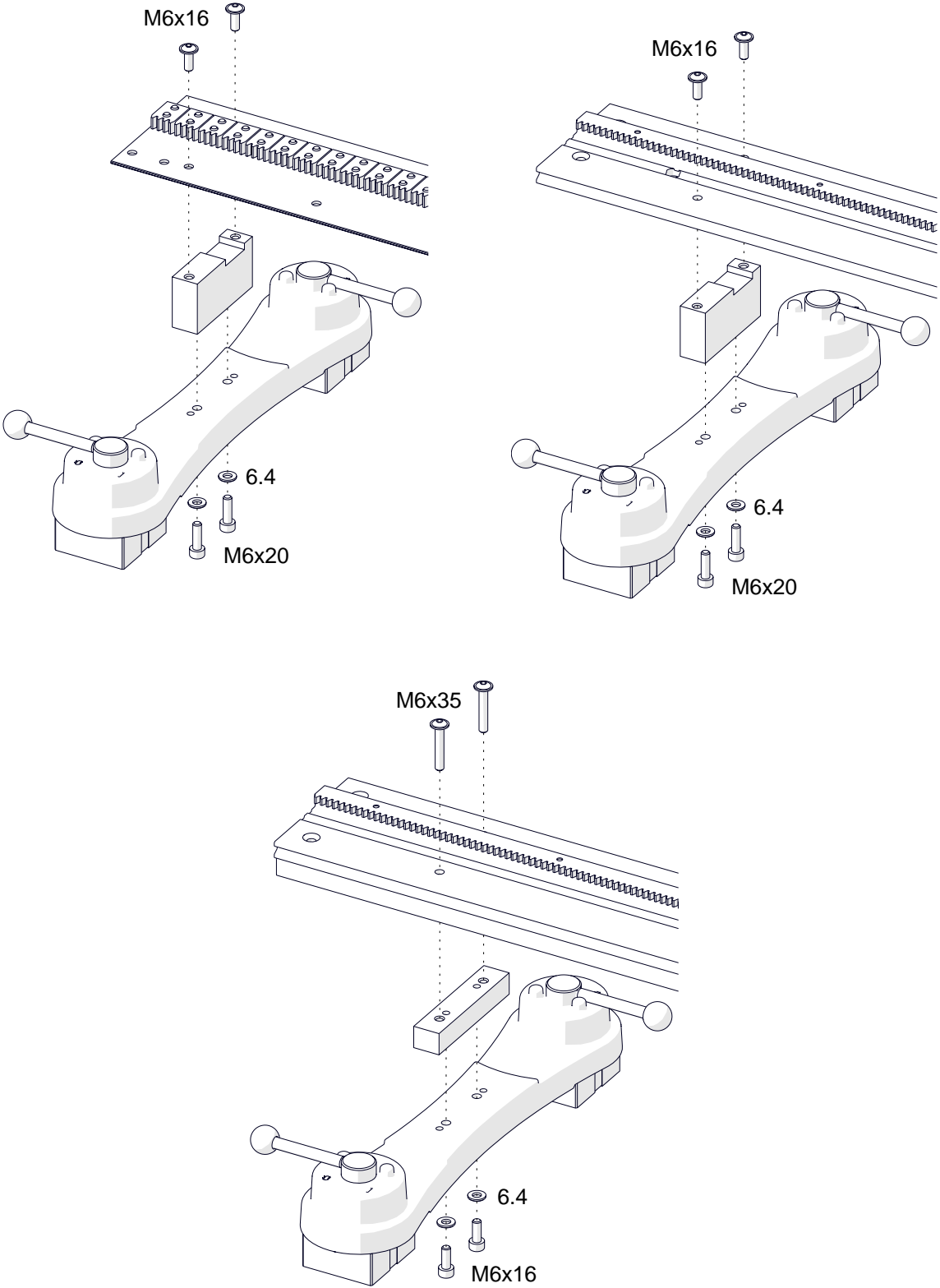

5.10.2. Pivoting magnetic unit

Allows clamping a hi-flex, semi-flex, or rigid track to ferromagnetic surfaces that are concave or convex, to pipes with outer diameters of at least 800 mm (31.5"), and to surfaces that differ in height up to 80 mm (3.1").

Part number:
ZSP-0475-85-00-00-0

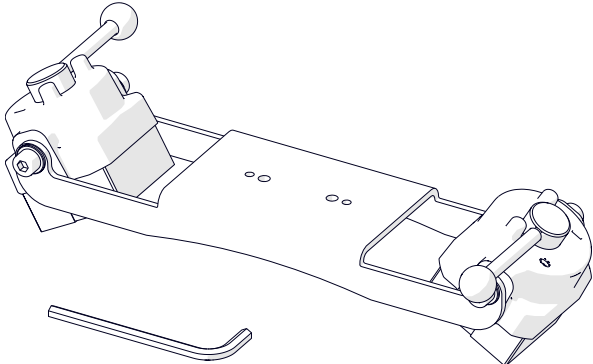

Part number (bracket for
hi-flex and semi-flex track):
DYS-0482-19-00-00-0

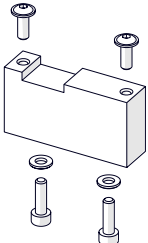

Part number (bracket for rigid
track):
DYS-0482-21-00-00-0

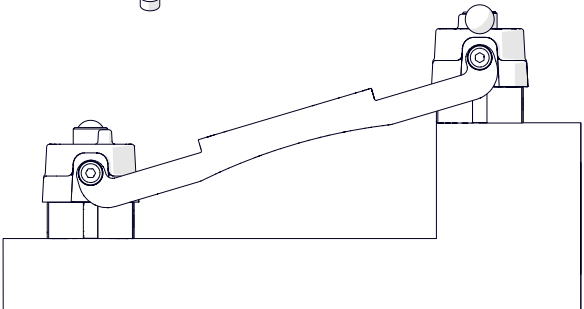
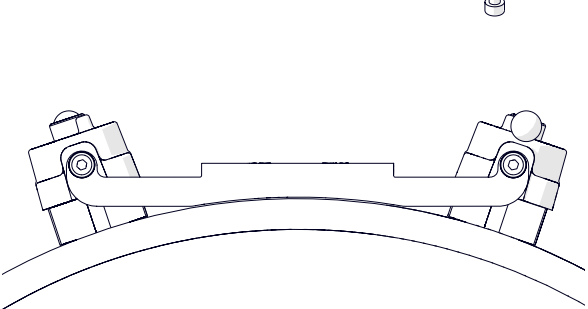
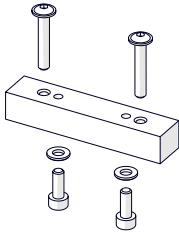

Holding force on a 5 mm (0.2") thick surface	Temperature
100% (1200 N)	20°C (68°F)
75% (900 N)	80°C (176°F)
50% (600 N)	120°C (248°F)

Install the unit in the same way as the magnetic unit is installed. To adjust the angle, use the 6 mm hex wrench and loosen four side screws.

5.10.3. Spacing-adjustable magnetic unit

Allows clamping a hi-flex, semi-flex, or rigid track to two ferromagnetic pipes with diameters of 25–230 mm (1–9") and with distance between pipe axes of 170–230 mm (6.7–9.1").

Part number:
ZSP-0523-19-00-00-0

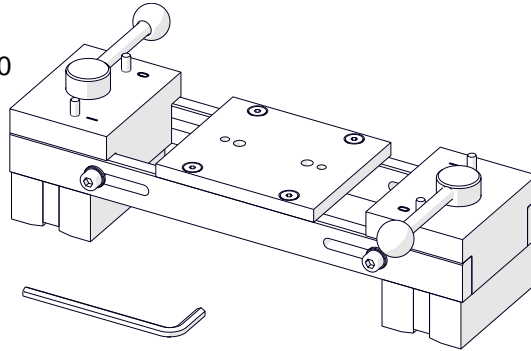

Part number (bracket for hi-flex and semi-flex track):
DYS-0482-19-00-00-0

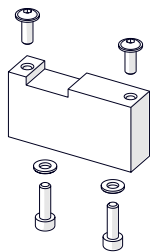

Part number (bracket for rigid track):
DYS-0482-21-00-00-0

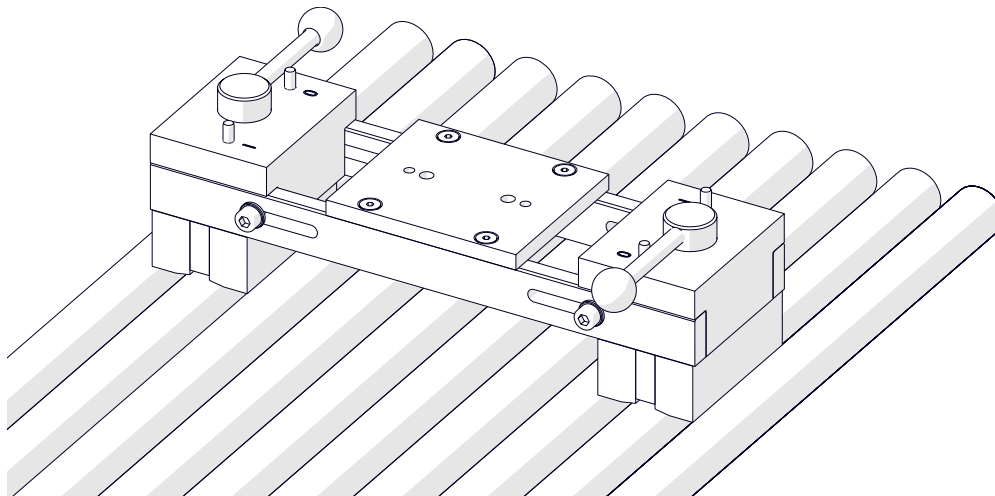
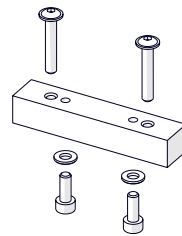

Holding force on a 5 mm (0.2") thick surface	Temperature
100% (1200 N)	20°C (68°F)
75% (900 N)	80°C (176°F)
50% (600 N)	120°C (248°F)

Install the unit in the same way as the magnetic unit is installed. To adjust the spacing, use the 5 mm hex wrench and loosen four side screws.

5.10.4. Narrow magnetic unit

Allows clamping a hi-flex, semi-flex, or rigid track to ferromagnetic surfaces.

Part number:
PDS-0582-10-00-02-0

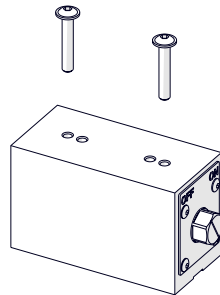

Part number (bracket for hi-flex and semi-flex track):
DYS-0582-10-00-00-0

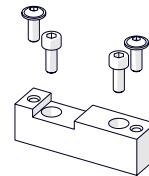

Holding force on a 5 mm (0.2") thick surface	Temperature
100% (1000 N)	20°C (68°F)
75% (750 N)	80°C (176°F)
50% (500 N)	120°C (248°F)

Use the 4 mm hex wrench to attach the unit to the tracks as shown in the figures.

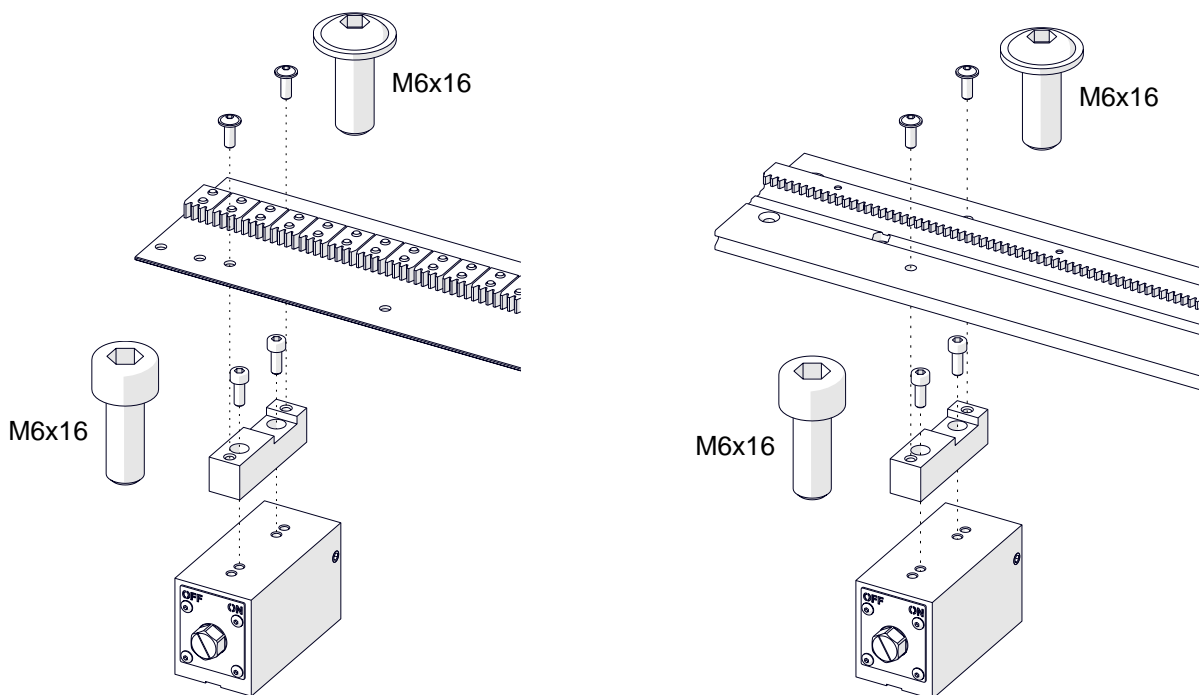

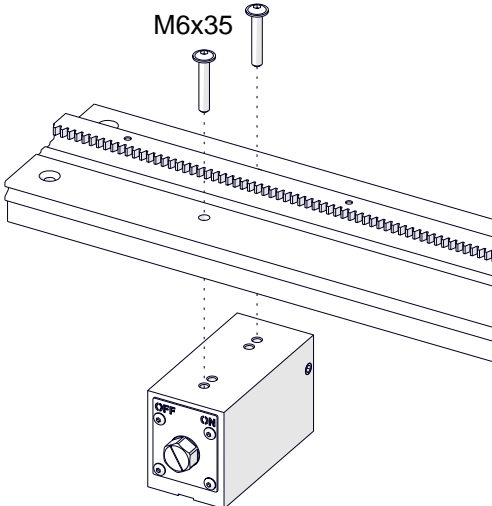

To clamp the unit to the surface, use the 17 mm flat wrench (not included) and set the side screw to ON.

5.11. Semi-flex track support

Allows supporting a semi-flex track by using the support instead of a magnetic unit or narrow magnetic unit. Use the 4 mm hex wrench to attach the support.

Part number:
WSP-0523-12-01-00-1

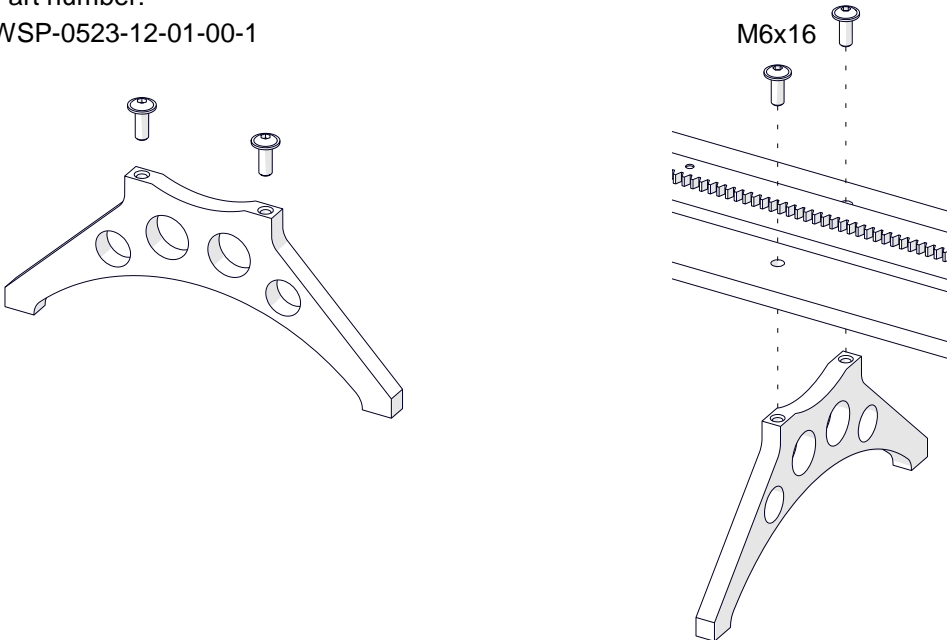

5.12. Vacuum track system

Allows clamping a hi-flex, semi-flex, or rigid track to non-ferromagnetic surfaces.

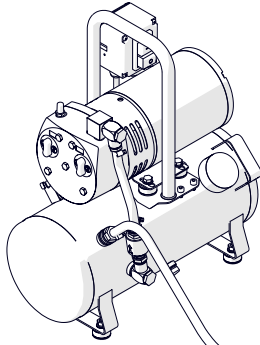

Part number (vacuum pump with safety reservoir):
AGR-0541-10-10-00-0 (115 V UK)
AGR-0541-10-20-00-0 (230 V CEE)

Other parts of the system are described in a related manual.

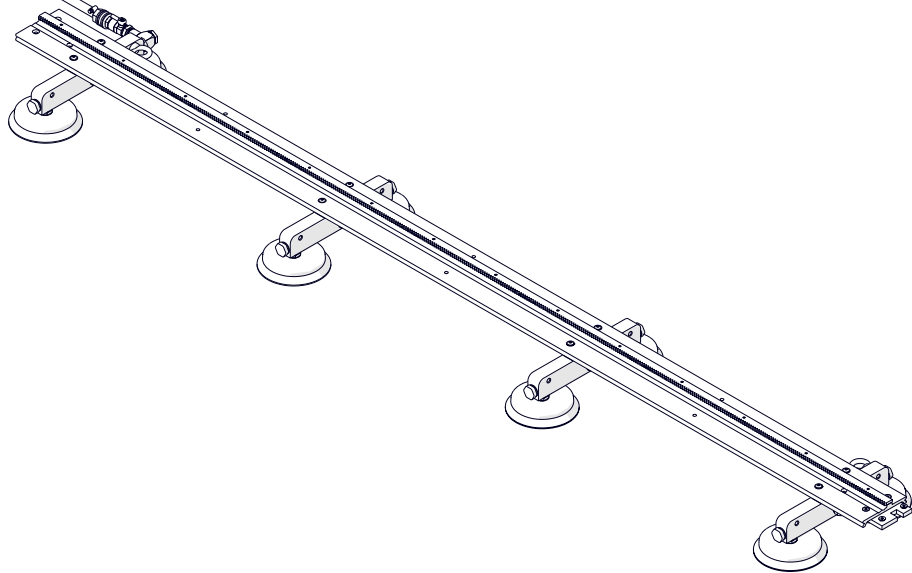

5.13. Ring tracks

Allow welding of round workpieces with the outer diameters from 200 mm (8") to 3000 mm (120"). The tracks consist of two, three, or four rails. Tracks not shown in the table are available on request.

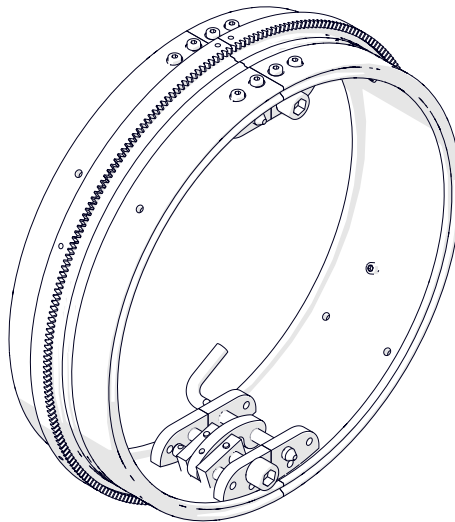

Pipe outer diameter		Part number	Rails	Ring track supports required
Min. [mm]	Max. [mm]			
200	250	TRO-0523-14-00-00-0	2	4
250	300	TRO-0523-78-00-00-0	2	4
300	350	TRO-0523-20-00-00-0	2	4
350	400	TRO-0523-21-00-00-0	2	4
400	450	TRO-0523-23-00-00-0	2	6
450	500	TRO-0523-24-00-00-0	2	6
500	550	TRO-0523-25-00-00-0	2	6
550	600	TRO-0523-26-00-00-0	2	6
600	650	TRO-0523-22-00-00-0	2	6
650	700	TRO-0523-28-00-00-0	2	6
700	750	TRO-0523-29-00-00-0	2	6
750	800	TRO-0523-30-00-00-0	2	6
800	850	TRO-0523-31-00-00-0	2	6
850	900	TRO-0523-32-00-00-0	2	6
900	950	TRO-0523-33-00-00-0	2	8
950	1000	TRO-0523-34-00-00-0	2	8
1000	1050	TRO-0523-35-00-00-0	2	8
1050	1100	TRO-0523-36-00-00-0	3	9
1100	1150	TRO-0523-37-00-00-0	3	9
1150	1200	TRO-0523-38-00-00-0	3	9
1200	1250	TRO-0523-39-00-00-0	3	9
1250	1300	TRO-0523-40-00-00-0	3	9

This document is protected by copyrights.

Copying, using, or distributing without permission of JEI Group Ltd is prohibited.

Pipe outer diameter		Part number	Rails	Ring track supports required
Min. [mm]	Max. [mm]			
1300	1350	TRO-0523-41-00-00-0	3	12
1350	1400	TRO-0523-42-00-00-0	3	12
1400	1450	TRO-0523-43-00-00-0	3	12
1450	1500	TRO-0523-44-00-00-0	3	12
1500	1550	TRO-0523-45-00-00-0	3	12
1550	1600	TRO-0523-46-00-00-0	3	12
1600	1650	TRO-0523-47-00-00-0	3	12
1650	1700	TRO-0523-48-00-00-0	3	12
1700	1750	TRO-0523-49-00-00-0	3	12
1750	1800	TRO-0523-50-00-00-0	3	12
1800	1850	TRO-0523-51-00-00-0	3	12
1850	1900	TRO-0523-52-00-00-0	3	15
1900	1950	TRO-0523-53-00-00-0	3	15
1950	2000	TRO-0523-54-00-00-0	3	15
2000	2050	TRO-0523-55-00-00-0	3	15
2050	2100	TRO-0523-56-00-00-0	4	16
2100	2150	TRO-0523-57-00-00-0	4	16
2150	2200	TRO-0523-58-00-00-0	4	16
2200	2250	TRO-0523-59-00-00-0	4	16
2250	2300	TRO-0523-60-00-00-0	4	20
2300	2350	TRO-0523-61-00-00-0	4	20
2350	2400	TRO-0523-62-00-00-0	4	20
2400	2450	TRO-0523-63-00-00-0	4	20
2450	2500	TRO-0523-64-00-00-0	4	20
2500	2550	TRO-0523-65-00-00-0	4	20
2550	2600	TRO-0523-66-00-00-0	4	20
2600	2650	TRO-0523-67-00-00-0	4	20
2650	2700	TRO-0523-68-00-00-0	4	20
2700	2750	TRO-0523-69-00-00-0	4	20
2750	2800	TRO-0523-70-00-00-0	4	20
2800	2850	TRO-0523-71-00-00-0	4	20
2850	2900	TRO-0523-72-00-00-0	4	20
2900	2950	TRO-0523-73-00-00-0	4	20
2950	3000	TRO-0523-74-00-00-0	4	20
3000	3050	TRO-0523-75-00-00-0	4	20

5.14. Ring track supports

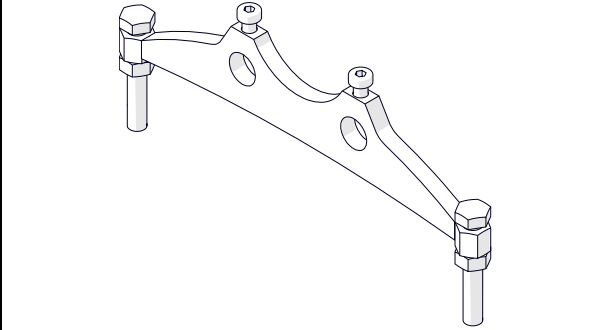
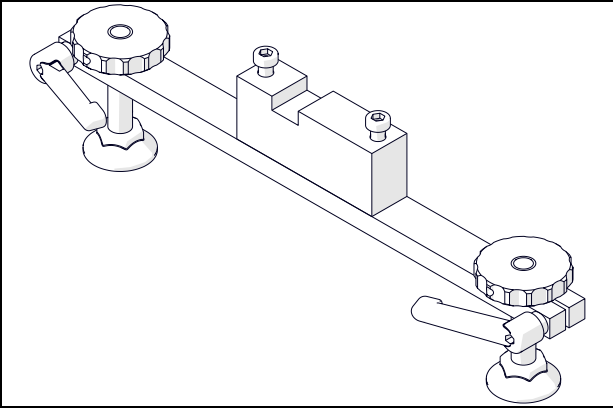
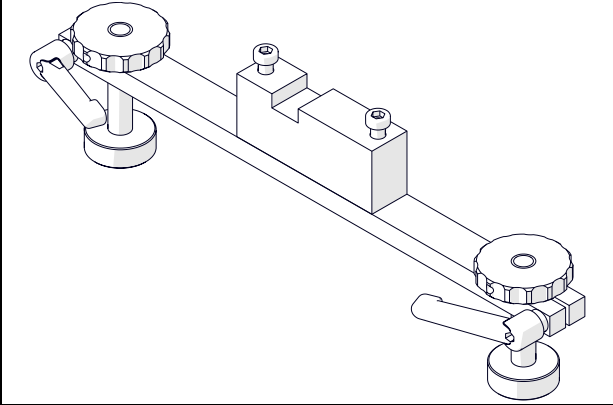
Ring track support with bolts	
	Part number: WSP-0523-14-02-00-0
Ring track support with plastic feet	
	Part number: WSP-0523-14-11-00-0
Ring track support with magnets	
	Part number: WSP-0523-14-12-00-0

5.15. Torch holders, clamps, and rods

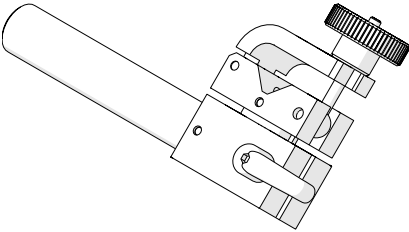
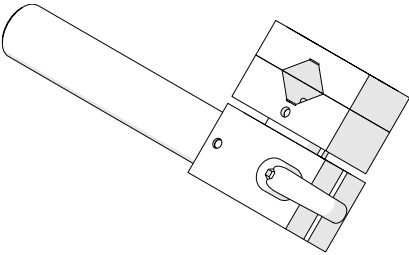
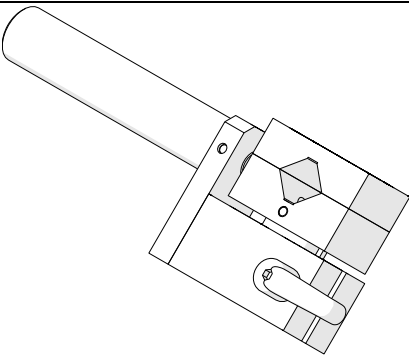
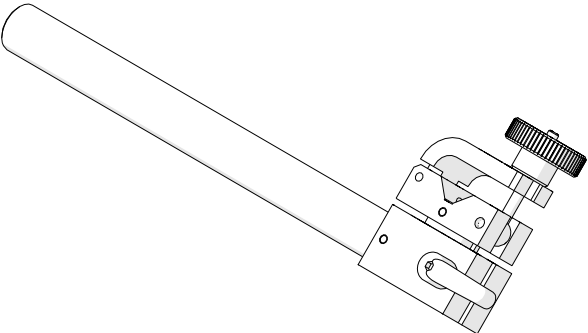
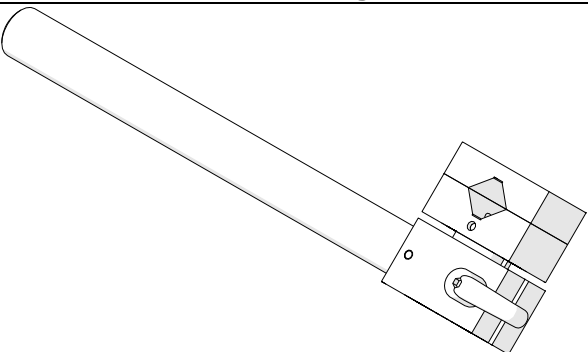
Short rod torch holder with clamp 16–22 mm	
	Part number: UCW-0476-20-00-00-0
Short rod torch holder with clip 16–22 mm	
	Part number: UCW-0476-27-00-00-0
Short low rod torch holder with clip 16–22 mm	
	Part number: UCW-0476-06-00-00-0
Long rod torch holder with clamp 16–22 mm	
	Part number: UCW-0466-04-00-00-0
Long rod torch holder with clip 16–22 mm	
	Part number: UCW-0466-22-00-00-0

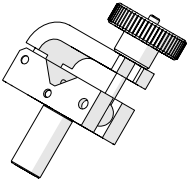
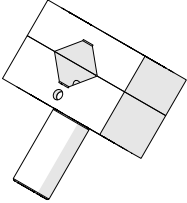
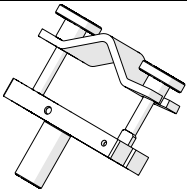
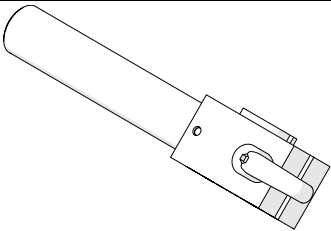
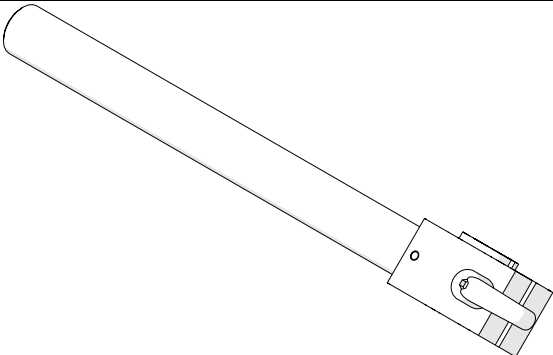
Torch clamp 16–22 mm	
	Part number: ZRZ-0466-04-01-00-0
Torch clip 16–22 mm	
	Part number: ZCS-0476-06-01-00-0
Torch clamp 22–35 mm	
	Part number: ZRZ-0466-19-00-00-0
Short rod	
	Part number: WLK-0476-20-01-00-0
Long rod	
	Part number: WLK-0466-04-10-00-0

5.16. Transport attachment

Allows transporting the wire feeder.

Part number:
PEP-0523-93-00-00-0

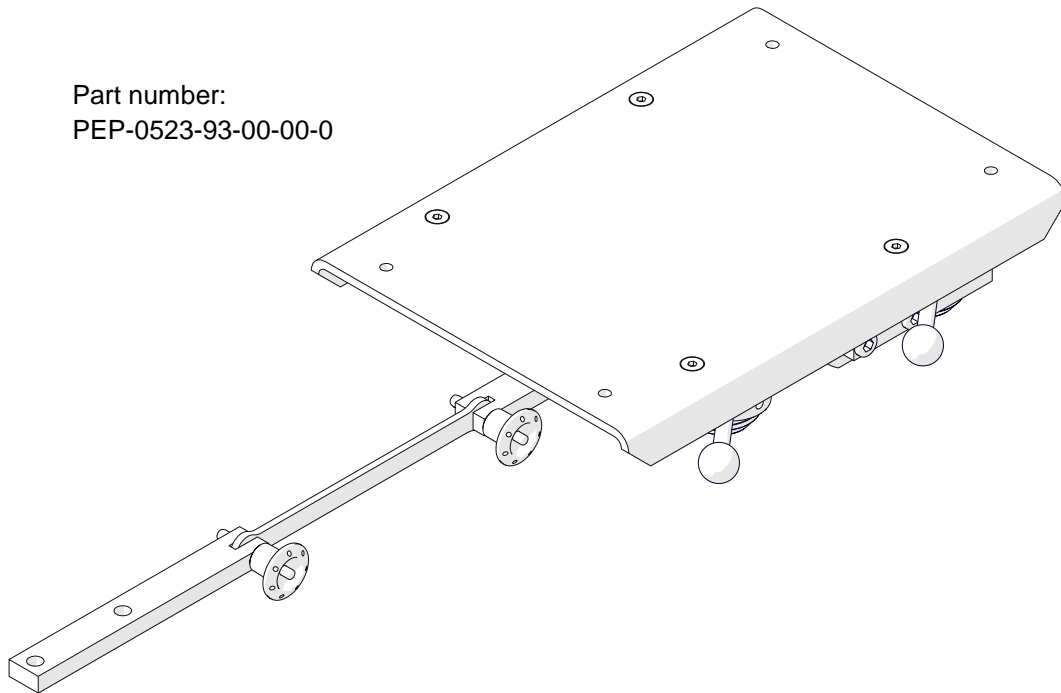

5.17. Pendulum oscillator

Allows pendulum oscillation of MIG/MAG torches with the diameter of 16–22 mm (5/8–7/8"). Can work with an optional seam tracking attachment. To work without the attachment, use a 203 mm rod and a clamping block.

Part number:
OSC-0497-10-00-00-0

Part number:
KLM-0236-00-16-00-0 (203 mm rod)
KST-0525-11-00-00-0 (Clamping block)

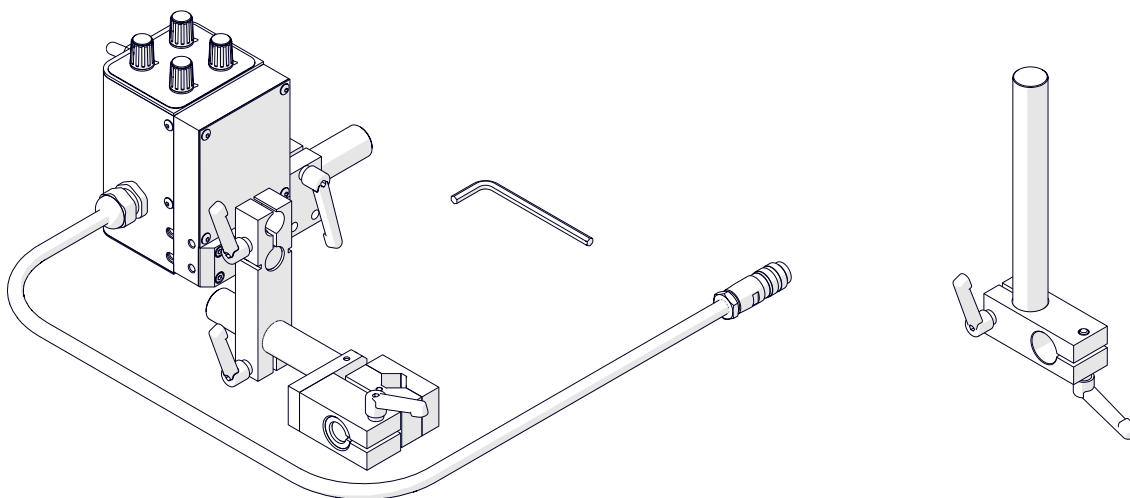

To use the oscillator without seam tracking, assemble the oscillator with a 203 mm (8") rod and a clamping block (1). Use the 80 mm (3") rod to put the oscillator onto the carriage (2). Next, set the switch to the middle position (3) and connect the oscillator to the carriage (4).

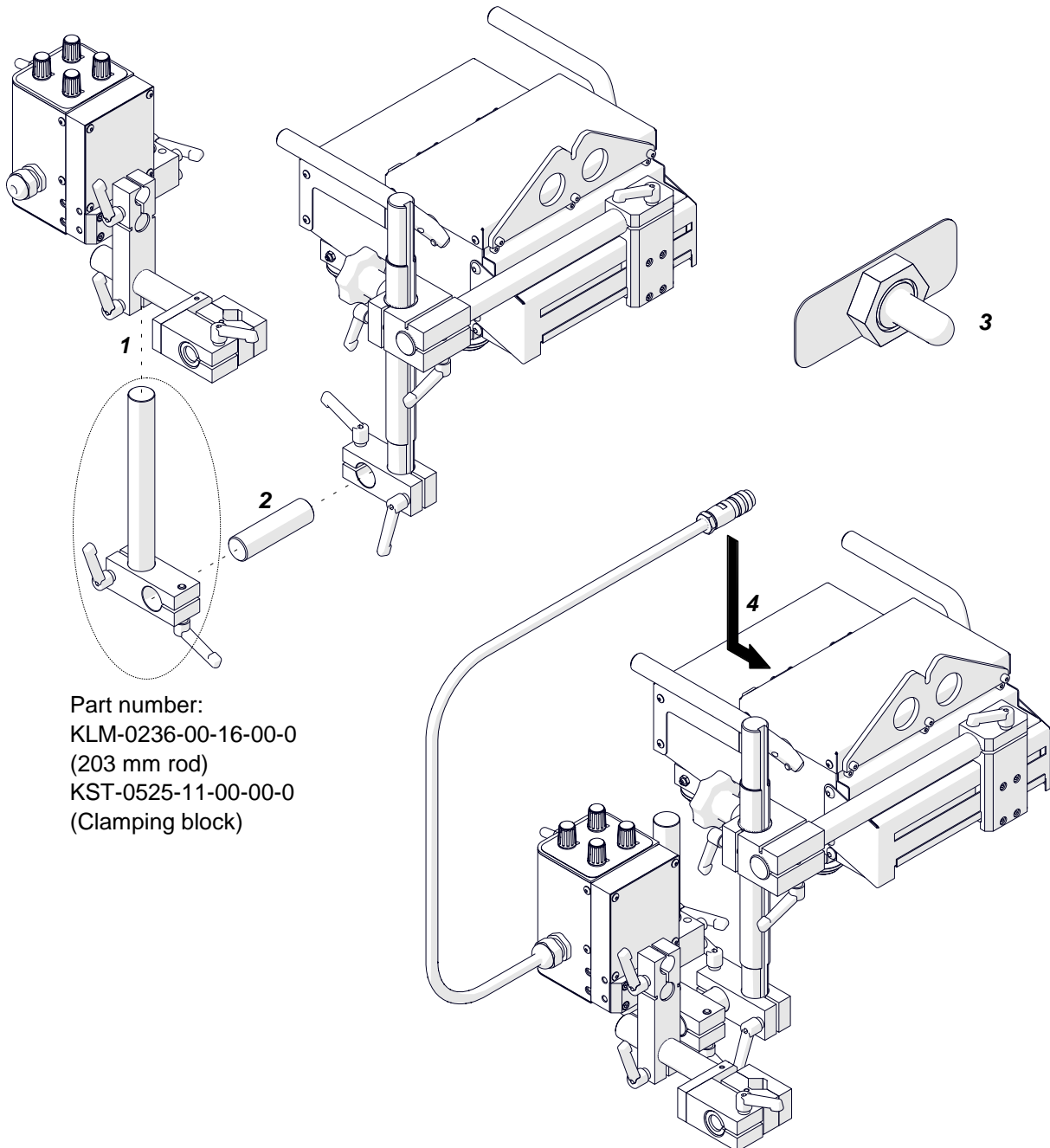

Part number:
 KLM-0236-00-16-00-0
 (203 mm rod)
 KST-0525-11-00-00-0
 (Clamping block)

To use the oscillator with seam tracking, put the oscillator onto the carriage with the installed seam tracking attachment (1). Next, set the switch to the center position (2) and connect the oscillator to the tracking sensor (3).

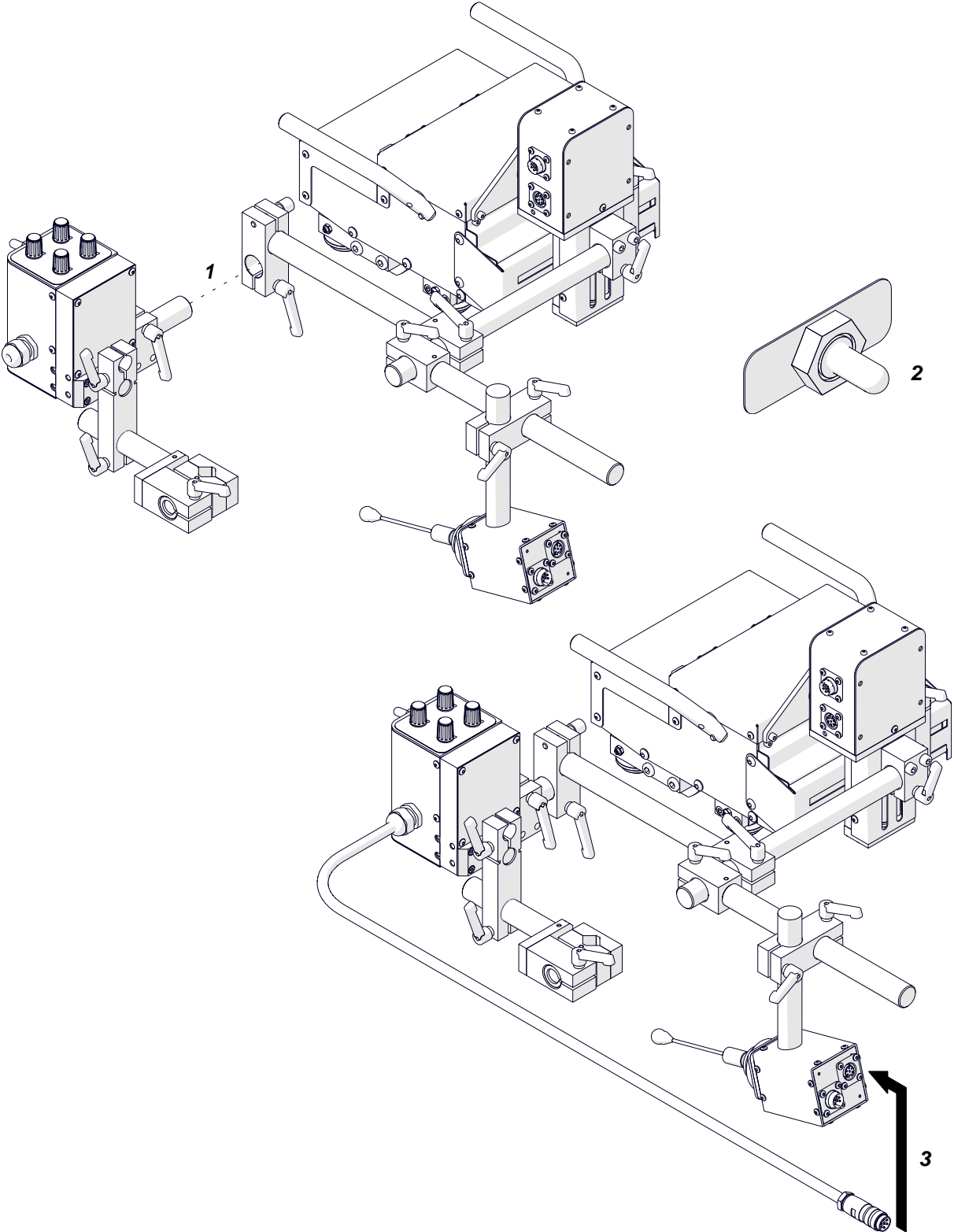

6. WIRING DIAGRAM

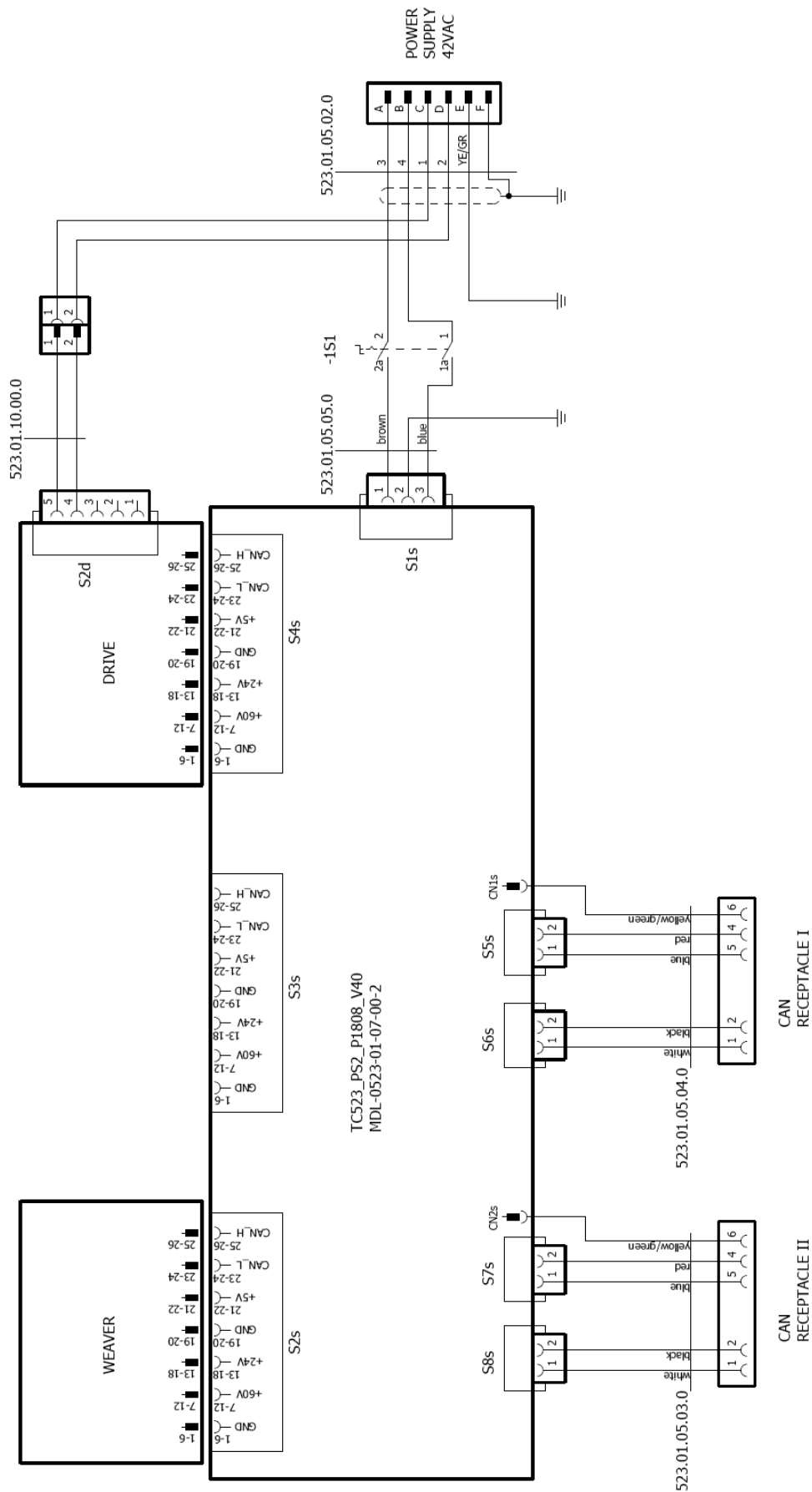

This document is protected by copyrights.

Copying, using, or distributing without permission of JEI Group Ltd is prohibited.

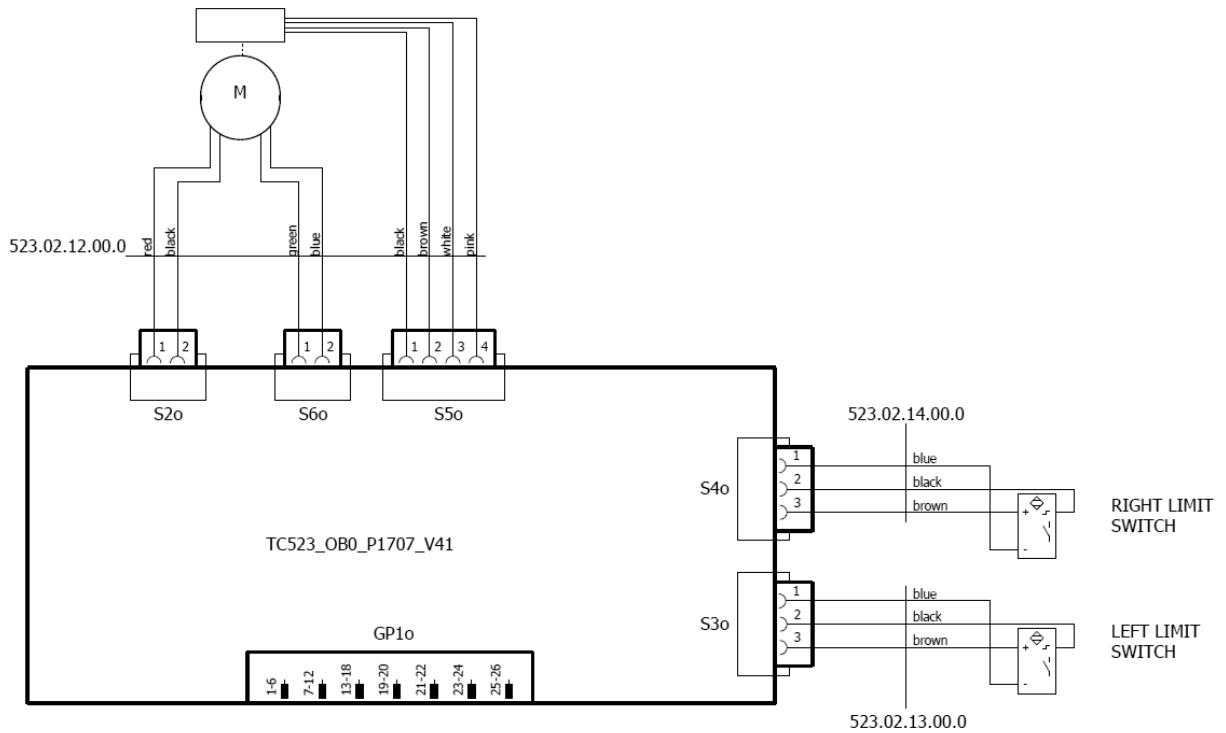
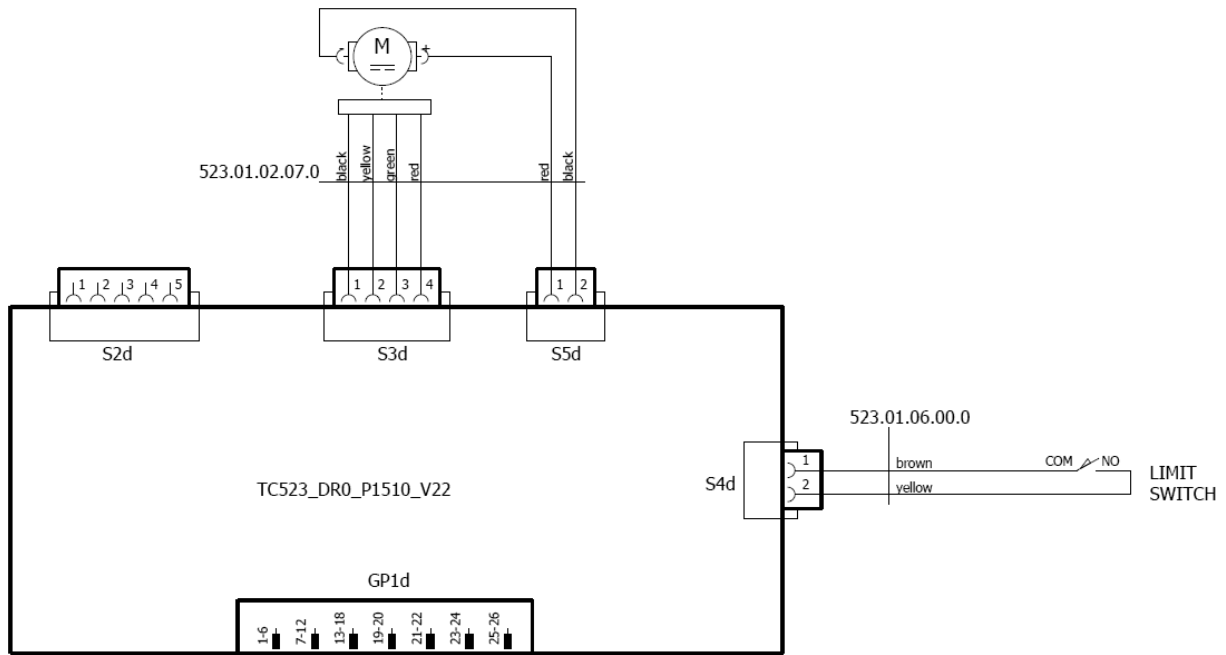

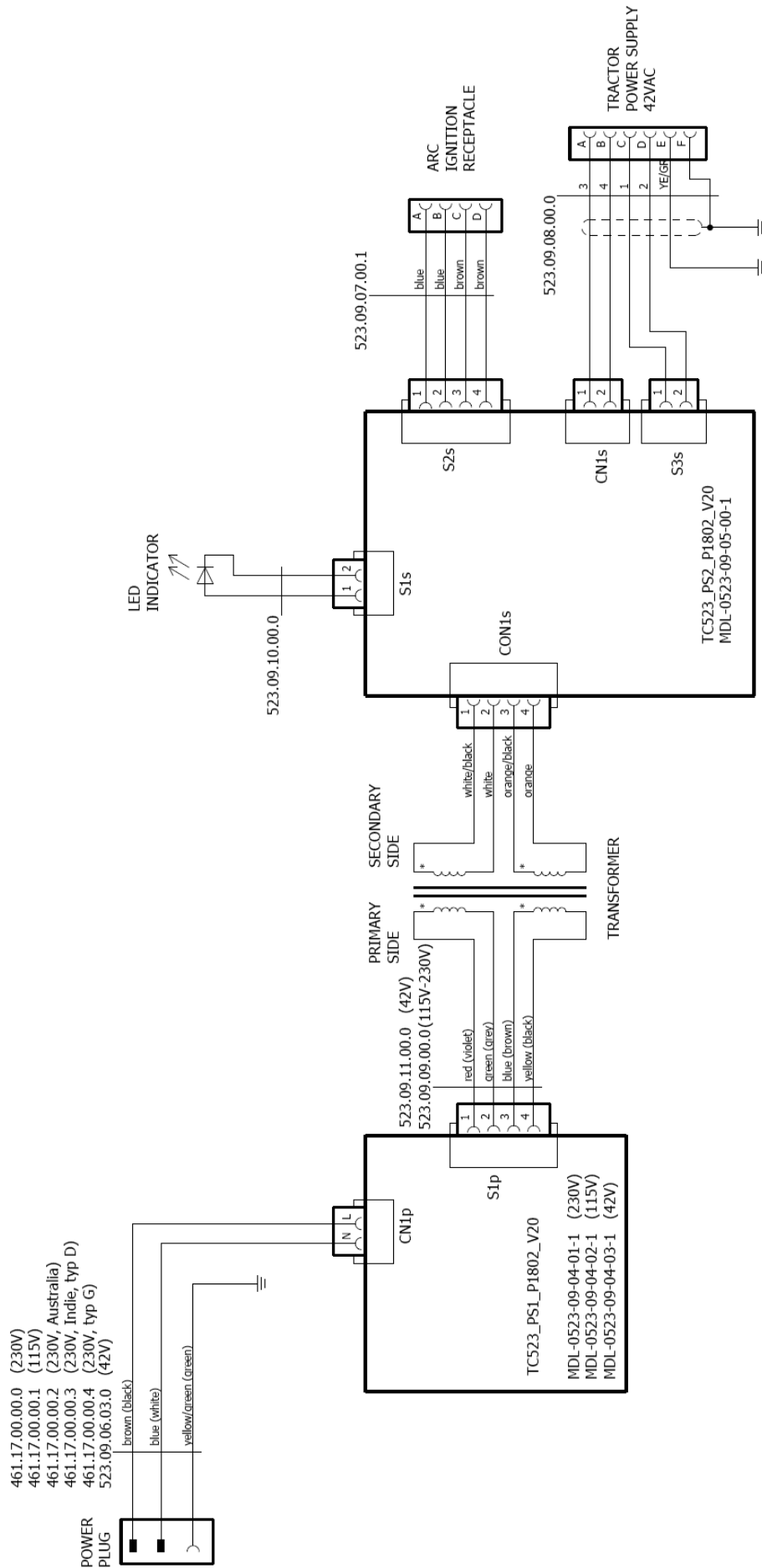

This document is protected by copyrights.

Copying, using, or distributing without permission of JEI Group Ltd is prohibited.

7. DECLARATION OF CONFORMITY

Declaration of Conformity

***JEI Group Ltd
Unit 21 Empire Business Park
Enterprise Way
Burnley
BB12 6LT***

We declare with full responsibility that:

Rail Bull 2 Welding Carriage

is manufactured in accordance with the following standards:

- EN 12100
- EN 60745-1
- EN 60974-10

and satisfies regulations of the guidelines: 2004/108/EC, 2006/95/EC, 2006/42/EC.

Person authorized to compile the technical file:

David McFadden, Unit 21 Empire Business Park, Burnley

Burnley, 10 December 2015



David McFadden
Managing Director

8. WARRANTY CARD

WARRANTY CARD No.....

..... in the name of Manufacturer warrants the Rail Bull 2 Welding Carriage to be free of defects in material and workmanship under normal use for a period of 12 months from the date of sale.

This warranty does not cover rollers as well as damage or wear that arise from misuse, accident, tempering, or any other causes not related to defects in workmanship or material.

Date of production

Serial number

Date of sale

Signature and stamp of the seller

1.11 / 19 April 2019

WE RESERVE THE RIGHT TO MAKE CHANGES IN THIS MANUAL WITHOUT NOTICE